

DIH10, DIH10-Ex



Connection Head with digital Indicator

WIKA Alexander Wiegand GmbH & Co. KG
Alexander-Wiegand-Straße 30
63911 Klingenberg/Germany
Phone (+49) 93 72/132-0
Fax (+49) 93 72/132-406
E-Mail info@wika.de
www.wika.de



Important notice



Follow this instruction strictly: the use of the Ex type in Ex area is only allowed as long as the dummy jack is plugged on the pin plug for factory calibration!! (See picture page 2)



Safety warnings

General: When mounting, initiating and operating this indicator the safety precautions and regulations have to be observed. Only staff with a corresponding qualification should work with the indicator. A non-observance of the safety regulations may cause serious injuries and/or damages. Check before initial operation the suitability of the indicator for this area of application. The technical data of this manual have to be followed. **Never connect directly to a voltage supply (eg 24 VDC), that will destroy the indicator. Only use supply units which do not cross the electric limiting values.**

Additional notice for Ex models: Repairs are forbidden absolutely. It is not allowed to use indicators with external damages. Observe the notes for mounting and operating, the regulations for the use of equipment in Ex areas, too.

Electrical connection Model DIH10



Electrical connection Model DIH10-Ex



The use of these models in Ex areas is only allowed in intrinsically safe electric circuits.

In addition to this manual comply with the supplied EC Type-Test-Certificate (ZELM 03 ATEX 0163), too.



The current loop display is built in and used in a connection head BSZ-H or BSS-H (with or without wall mounting adaptor).

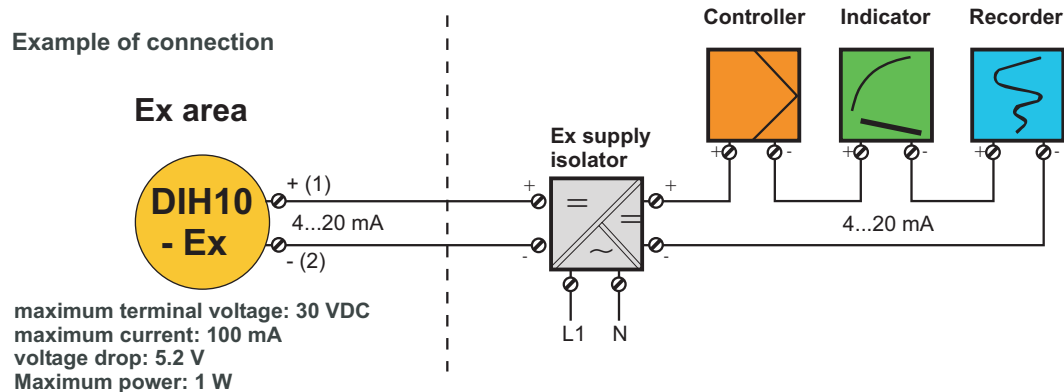

Important notice for Model DIH10-Ex



Comply strictly with: the use of the Ex type in Ex area is only allowed with a plugged dummy jack on the factory calibration connection!!

Only the manufacturer is to be allowed to use the programming set because there exists no ATEX- certification for it!!



The programming of the indicator has to be done with the three keys at the rear of the display only!!

View, dimension

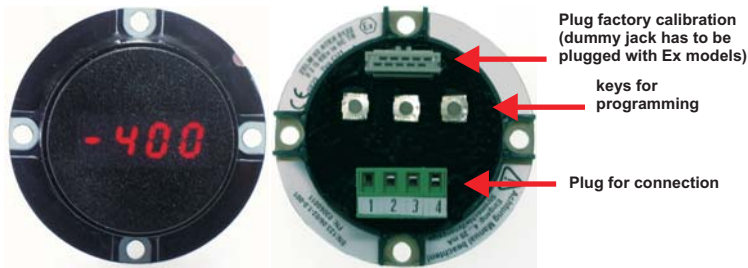

Program table for programming the indicator

PN	Description	Range	Factory-set
0	Calibration mode 0 = sensor calibration (one calibration point can be set) 1 = programming of indication (4/20 mA)	0/1	1
1	Final value (Programming the value, which is indicated at 20 mA, eg 600)	-999...9999	2000
2	Initial value (Programming the value, which is indicated at 4 mA eg 100)	-999...9999	400
3	Selection of decimal point or unit (Programming a unit the indication shifts to the left)	0 0.0 0.00 0.000 °F °C	0
4	Time of average / refresh of display	0,5...10,0	1,0
5	Offset base characteristic (the +/- range where 0000 is indicated)	0...100	1
50	Locking of programming (activating/deactivating locking function for programming)	0000...9999	0
51	Releasing code (definition of release code for the programming locking funtion under PN50)	0000...9999	0
100	Number of calibration setpoints (calibration points for sensor calibration only, calibration points reduce the measuring rate)	0...30	0
101...130	Calibration points	-999...9999	0

Programming of indication

1. Connect the instrument according to the wiring diagram.
2. Switch power of the current loop on (current between 4...20 mA). This is followed by an initialisation and a segment test with subsequent switching of the operation mode.
3. Press the **P** key. Indication of program number **P 0**.
4. Change the program number by simultaneous pressing of **P** & **▲** keys or **P** & **▼** keys.
5. With the desired program number being chosen, go to the allowed value by pressing the **▼** or **▲** key.
6. Short pressing of **P** results in a change of digit. The value of the chosen digit is changed by pressing the **▼** or **▲**.
7. Storing of the new settings is effected by pressing the **P** for approx. 2 sec. This procedure is acknowledged by transversal bars in the display.
8. If no other key is actuated, the unit switches to its operation mode after seven seconds.

Additional key functions in standard mode for indication of min/max values

The **▲** key serves for indicating the value of the Max memory in the display for some seconds

The **▼** key serves for indicating the value of the Min memory in the display for some seconds

Simultaneous pressing of the **▲** and **▼** keys erases the value of the memory shown in the display

Important



When changing the measurement range setting, the indicator always has to be recalibrated in order to maintain the measuring accuracy.

DIH10, DIH10-Ex



Technical data

Input

Measurement range	4...20 mA
Input resistance	R _i at 20 mA: < 250 ohms

Accuracy

Resolution	-999...+9999 digit -99...+999 digit unit is indicated
Measuring fault	+/-0,2% of measuring range, +/- 1 digit
Temperature drift	100 ppm/K
Measuring principle	ramp conversion

Indication

Display	LED with 7 segments, 8 mm high, red, 4 digits = indication 9999
Overflow/Underflow	to HI / to LO
Time of indication	0,1 s - 1 s - 10 s (adjustable)

Ambient conditions

Operating temperature	0...+60°C
Storing temperature	-20...+80°C

Mechanics

Housing	Ø 43/48,5/62,5 mm x 37mm
Assembly cut out	Ø 43,2 mm
Fastening	4 mounting holes M4
Housing material	Macrolon
Degree of protection	at the front IP 67 connection IP 20
Weight	approx. 40 g
Connection	at the rear via plug in connector up to 1,5 mm ²

Programmable features

Range of indication
Time of indication
Decimal point
4th digit to unit (°C/°F)

Specifications and dimensions given in this leaflet represent the state of engineering at the time of printing. Modifications may take place and materials specified may be replaced by others without prior notice.

WIKA Alexander Wiegand GmbH & Co. KG

Alexander-Wiegand-Straße 30
63911 Klingenberg/Germany
Phone (+49) 93 72/132-0
Fax (+49) 93 72/132-406
E-Mail info@wika.de
www.wika.de

