

Gas density indicator Model GDI-063

WIKA data sheet SP 60.21

Applications

- Medium-voltage equipment
- Gas density monitoring of closed SF₆ gas tanks

Special features

- Case and wetted parts from stainless steel
- On-site display of the pressure standardised to 20 °C [68 °F]
- Temperature-compensated and hermetically sealed, therefore no influence of temperature fluctuations, differences in level and atmospheric pressure fluctuations
- Traceability by serial number



Gas density indicator model GDI-063

Description

Gas density is a crucial operating parameter for medium-voltage systems. If the required gas density is not present, safe operation of the plant cannot be guaranteed.

With WIKA gas density measuring instruments, changes of gas volumes can be determined reliably (e.g. leakages). Even under extreme environmental conditions.

Numerous fields of application

The WIKA gas density indicator is hermetically sealed and temperature-compensated. Measured value fluctuations and misinterpretations caused by changes in either ambient temperature or atmospheric pressure are therefore prevented.

Via the on-site display, the pressure can be read directly on the instrument with reference to 20 °C [68 °F].

Gas density indicator

Nominal size

63

Calibration pressure P_E

To customer specification

Accuracy specifications

- ± 1 % of full scale (20 mbar, if measuring range < 2 bar) at an ambient temperature of 20 °C [68 °F]
- ± 2.5 % of full scale (50 mbar, if measuring range < 2 bar) at an ambient temperature of -20 ... +60 °C [-4 ... +140 °F]

The specified maximum deviation of 2.5 % refers to the limit temperatures (-20 °C and +60 °C [-4 °F and +140 °F]) at calibration pressure. The maximum deviation increases proportionally starting from 20 °C [68 °F].

Scale range

Vacuum and overpressure range with measuring span ≥ 1 bar (at an ambient temperature of 20 °C [68 °F] and gaseous phase)

Permissible ambient temperature

Operation: -20 ... +60 °C [-4 ... +140 °F], gaseous phase

Storage: -50 ... +60 °C [-58 ... +140 °F]

Process connection

G ¼ B per EN 837, lower mount

Stainless steel, spanner flats 14 mm

Other connections and connection locations on request.

Pressure element

Stainless steel, welded

Gas-tight: leak rate $\leq 1 \cdot 10^{-8}$ mbar · l / s

Test method: helium mass spectrometry

Movement

Stainless steel

Bimetal link (temperature compensation)

Dial

Aluminium

The scale range is subdivided into red, yellow and green ranges

Pointer

Aluminium, black

Case

Stainless steel, with gas filling

Gas-tight: leak rate $\leq 1 \cdot 10^{-5}$ mbar · l / s

Test method: Helium mass spectrometry

Window

Selectable versions

Option 1	Laminated safety glass
Option 2	Clear non-splintering plastic

Ring

Bayonet ring, stainless steel, secured by means of 3 welding spots

Permissible humidity

≤ 90 % r. h. (non-condensing)

Ingress protection

IP65 per EN 60529 / IEC 60529

Weight

approx. 160 g

Dimensions in mm

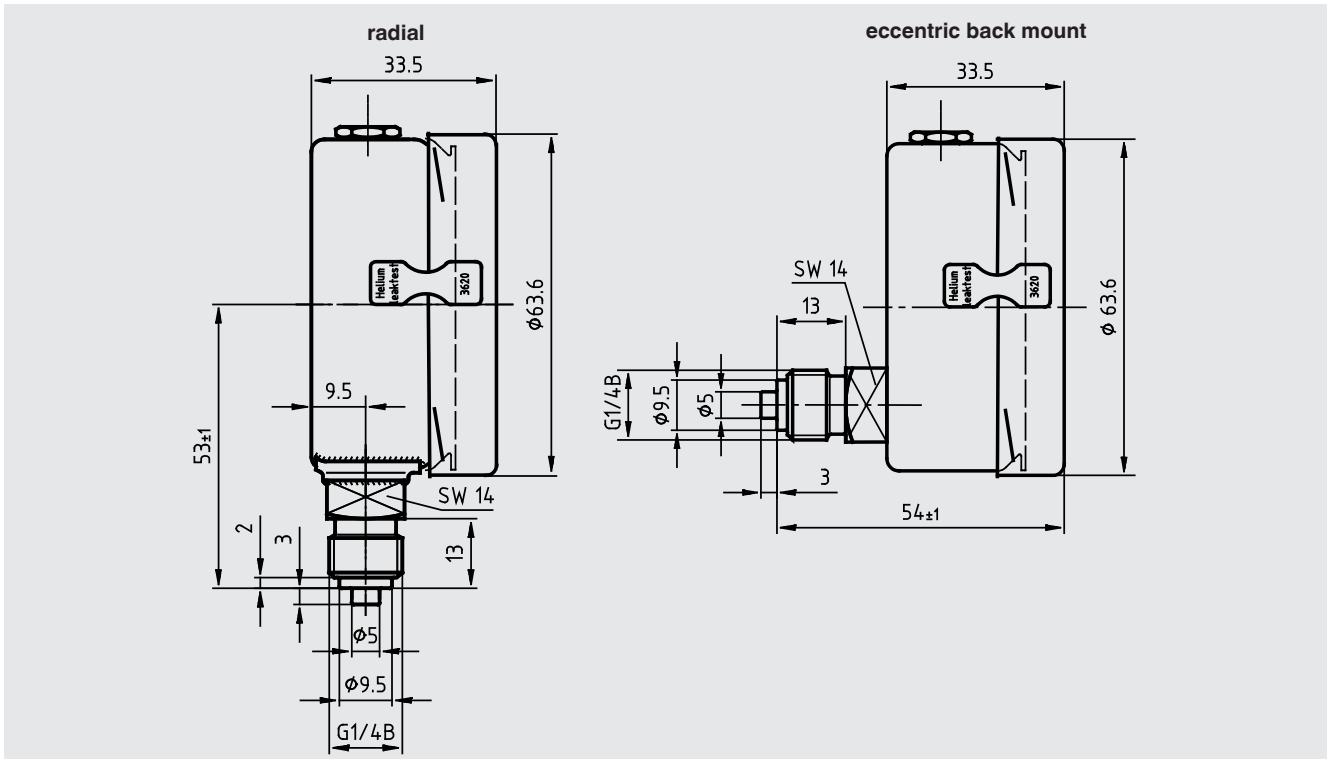

Ordering information

Model / Process connection / Pressure unit / Measuring range / Filling pressure / Gas mixture / Options

© 11/2015 WIKA Alexander Wiegand SE & Co. KG, all rights reserved.
 The specifications given in this document represent the state of engineering at the time of publishing.
 We reserve the right to make modifications to the specifications and materials.

