

Valve manifold for differential pressure measuring instruments

3-, 5-valve manifold

Models IV3, IV5

WIKA data sheet AC 09.23



For further approvals,
see page 13

Applications

- Shut-off, pressure equalising and vent valves for differential pressure measuring instruments
- For gaseous and liquid aggressive media that are not highly viscous or crystallising, also in aggressive environments
- Process industry: oil and gas, petrochemical, chemical industries, power generation, water and wastewater

Special features

- Low-wear design due to non-rotating spindle tip in the bonnet
- Low torque and smooth operation of valve handle even at high pressure
- Standardised centre distances of 37 mm and 54 mm, suitable for WIKA differential pressure gauges and commonly used process transmitters
- Valve seat tested for leak tightness per ISO 5208 leak rate A
- Enhanced working safety due to blow-out proof bonnet design, especially in applications with high pressure loading



Fig. top: model IV315, 3-valve manifold
Fig. bottom: model IV516, 5-valve manifold

Configurator



Standard articles



Description

3-valve manifold, model IV3

The 3-valve manifold consists of two shut-off valves and one pressure equalising valve. The shut-off valves separate the process from the differential pressure measuring instrument. The pressure equalising valve enables the compensation between \oplus side and \ominus side to avoid one-sided overpressure during commissioning and operation.

5-valve manifold, model IV5

Compared to the 3-valve manifold, the 5-valve manifold is equipped with two additional vent valves. One vent valve per pressure side allows operators the targeted venting of one or both pressure sides of the measuring arrangement.

The non-rotating spindle tip reduces wear of the sealing elements. This results, particularly with frequent opening and closing, in a noticeable increase in the service life.

The gas metering pattern for 5-valve manifolds features two pressure equalising valves, two shut-off valves and one vent valve. This provides ideal differential pressure measurement and ensures stable measuring results.

The natural gas design, model IV52N, is available with soft-seat through-bore bonnets that enable both instrument shut-off and flow control.

On request, WIKA offers the professional assembly of valves and pressure measuring instruments and also other accessories into a ready-to-install instrument hook-up.

Model overview for IV3

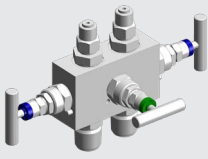
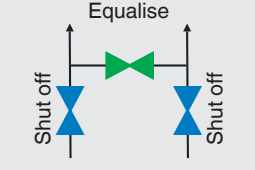
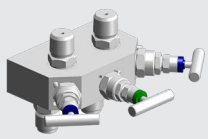
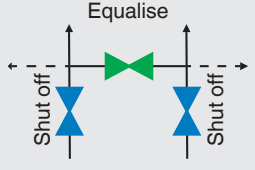
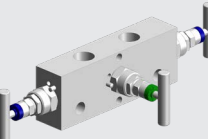
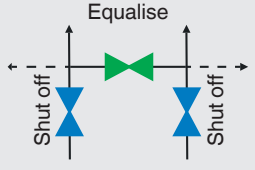
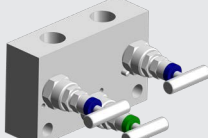
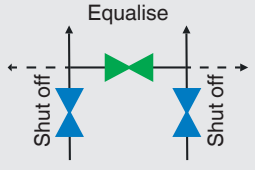
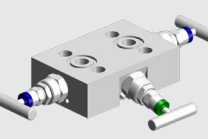
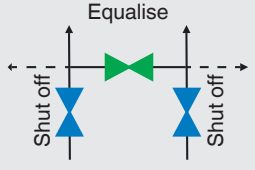
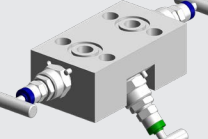
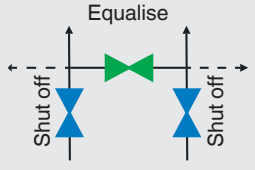
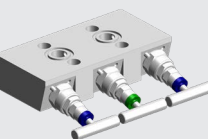
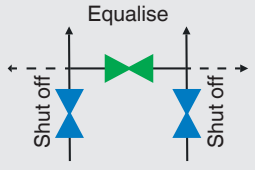
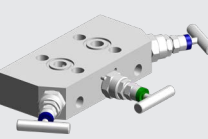
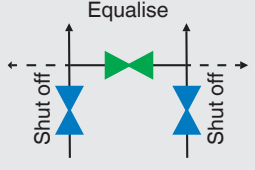
Model	Description	Functional diagram
	<p>IV304</p> <ul style="list-style-type: none"> ■ 3-valve manifold ■ Centre distance on instrument side: 37 mm [1.46 in] ■ Angled bonnet position 	
	<p>IV315</p> <ul style="list-style-type: none"> ■ 3-valve manifold ■ Centre distance on instrument side: 54 mm [2.12 in] ■ Radial bonnet position 	
	<p>IV319</p> <ul style="list-style-type: none"> ■ 3-valve manifold ■ Centre distance on instrument side: 54 mm [2.12 in] ■ Angled bonnet position 	
	<p>IV313</p> <ul style="list-style-type: none"> ■ 3-valve manifold ■ Centre distance on instrument side: 54 mm [2.12 in] ■ Side-by-side bonnet position 	
	<p>IV316</p> <ul style="list-style-type: none"> ■ 3-valve manifold ■ Centre distance on instrument side: 54 mm [2.12 in] ■ Angled bonnet position ■ Direct flange mounting 	
	<p>IV318</p> <ul style="list-style-type: none"> ■ 3-valve manifold ■ Centre distance on instrument side: 54 mm [2.12 in] ■ Angled bonnet position, equalising valve under 45° ■ Direct flange mounting 	
	<p>IV31V</p> <ul style="list-style-type: none"> ■ 3-valve manifold ■ Centre distance on instrument side: 54 mm [2.12 in] ■ Centre distance on process side: 110 mm [4.33 in] ■ Angled bonnet position ■ Direct flange mounting 	
	<p>IV31E</p> <ul style="list-style-type: none"> ■ 3-valve manifold ■ Centre distance on instrument side: 54 mm [2.12 in] ■ Radial bonnet position ■ Direct flange mounting 	

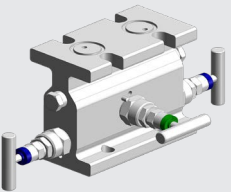
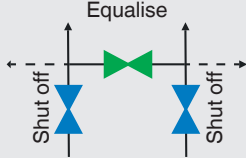
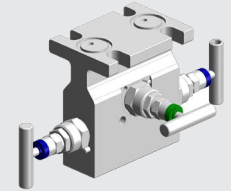
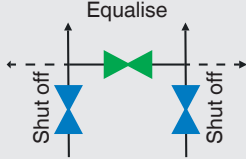
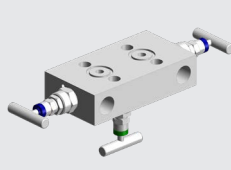
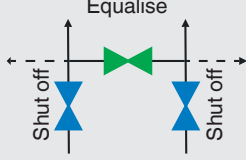
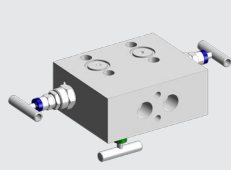
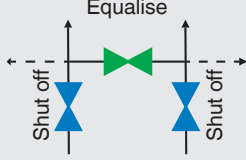
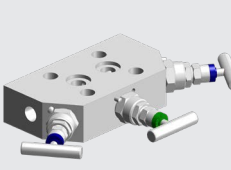
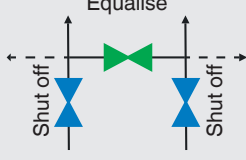
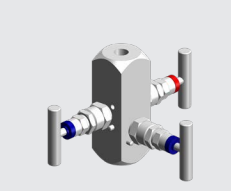
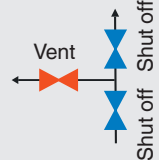
Model		Description	Functional diagram
	IV31H	<ul style="list-style-type: none"> ■ 3-valve manifold ■ Centre distance on instrument side: 54 mm [2.12 in] ■ Angled bonnet position ■ H-shaped design ■ Direct flange mounting 	
	IV31T	<ul style="list-style-type: none"> ■ 3-valve manifold ■ Centre distance on instrument side: 54 mm [2.12 in] ■ Angled bonnet position ■ T-shaped design ■ Direct flange mounting 	
	IV31D	<ul style="list-style-type: none"> ■ 3-valve manifold ■ Centre distance on instrument side: 54 mm [2.12 in] ■ Angled bonnet position, equalising valve under 90° ■ Direct flange mounting with 90° angle connections 	
	IV31S	<ul style="list-style-type: none"> ■ 3-valve manifold ■ Centre distance on instrument side: 54 mm [2.12 in] ■ Angled bonnet position ■ Direct flange mounting with 90° angle connections ■ Special design for protective enclosures 	
	IV31R	<ul style="list-style-type: none"> ■ 3-valve manifold ■ Centre distance on instrument side: 54 mm [2.12 in] ■ Radial bonnet position ■ Integral flange mounting 	
	IV3D9	<ul style="list-style-type: none"> ■ 3-valve manifold ■ Double block-and-bleed setup ■ Angled bonnet position 	

Model overview for IV5

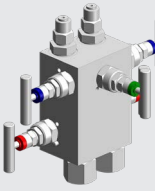
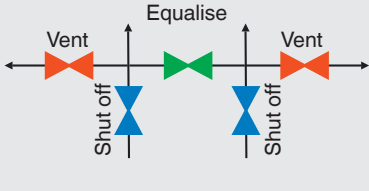
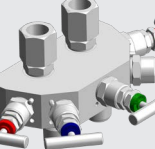
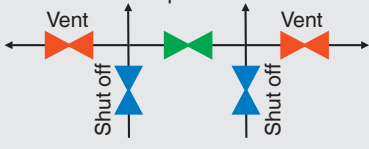
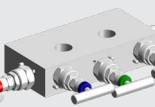
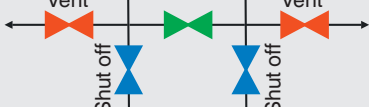
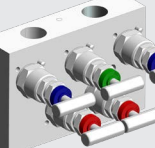
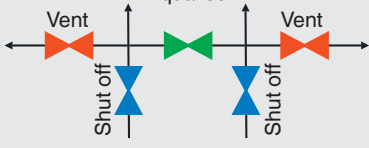
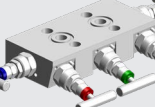
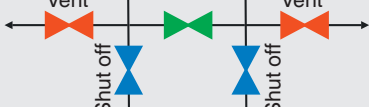
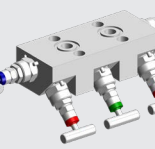
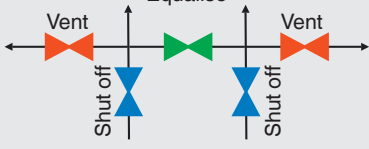
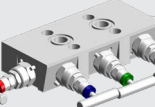
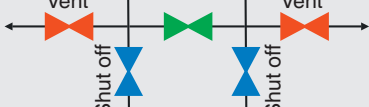
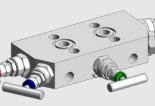
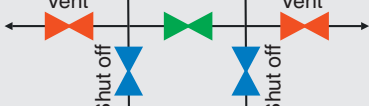
Model	Description	Functional diagram
	<ul style="list-style-type: none"> 5-valve manifold Centre distance on instrument side: 37 mm [1.46 in] Angled bonnet position 	
	<ul style="list-style-type: none"> 5-valve manifold Centre distance on instrument side: 54 mm [2.12 in] Radial bonnet position 	
	<ul style="list-style-type: none"> 5-valve manifold Centre distance on instrument side: 54 mm [2.12 in] Angled bonnet position 	
	<ul style="list-style-type: none"> 5-valve manifold Centre distance on instrument side: 54 mm [2.12 in] Side-by-side bonnet position 	
	<ul style="list-style-type: none"> 5-valve manifold Centre distance on instrument side: 54 mm [2.12 in] Angled bonnet position Direct flange mounting 	
	<ul style="list-style-type: none"> 5-valve manifold Centre distance on instrument side: 54 mm [2.12 in] Angled bonnet position, vent and equalising valves under 45° Direct flange mounting 	
	<ul style="list-style-type: none"> 5-valve manifold Centre distance on instrument side: 54 mm [2.12 in] Centre distance on process side: 110 mm [4.33 in] Angled bonnet position Direct flange mounting 	
	<ul style="list-style-type: none"> 5-valve manifold Centre distance on instrument side: 54 mm [2.12 in] Radial bonnet position Direct flange mounting 	

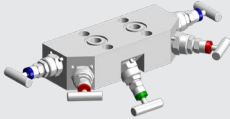
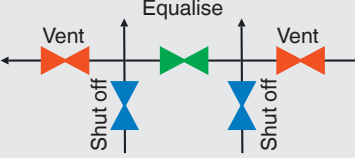
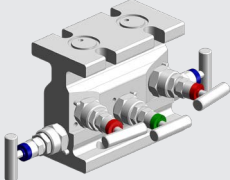
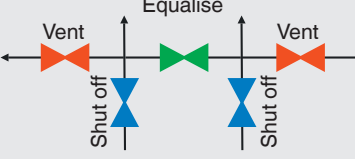
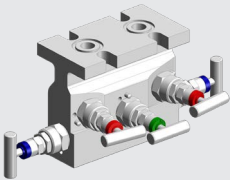
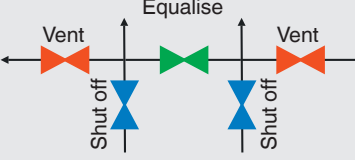
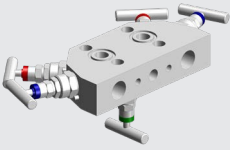
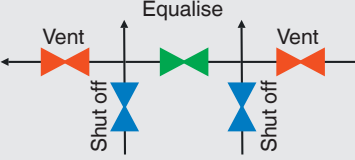
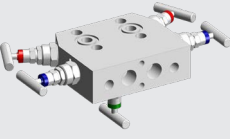
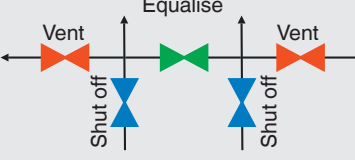
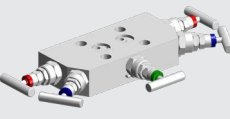
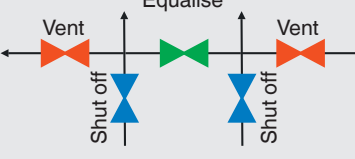
Model		Description	Functional diagram
	IV51G	<ul style="list-style-type: none"> ■ 5-valve manifold ■ Centre distance on instrument side: 54 mm [2.12 in] ■ Radial bonnet position, equalising valve under 45° ■ Direct flange mounting 	
	IV51H	<ul style="list-style-type: none"> ■ 5-valve manifold ■ Centre distance on instrument side: 54 mm [2.12 in] ■ Angled bonnet position ■ H-shaped design ■ Direct flange mounting 	
	IV51T	<ul style="list-style-type: none"> ■ 5-valve manifold ■ Centre distance on instrument side: 54 mm [2.12 in] ■ Angled bonnet position ■ T-shaped design ■ Direct flange mounting 	
	IV51D	<ul style="list-style-type: none"> ■ 5-valve manifold ■ Centre distance on instrument side: 54 mm [2.12 in] ■ Radial bonnet position, equalising valve under 90° ■ Direct flange mounting with 90° angle connections 	
	IV51S	<ul style="list-style-type: none"> ■ 5-valve manifold ■ Centre distance on instrument side: 54 mm [2.12 in] ■ Radial bonnet position, equalising valve under 90° ■ Direct flange mounting with 90° angle connections ■ Special design for protective enclosures 	
	IV51R	<ul style="list-style-type: none"> ■ 5-valve manifold ■ Centre distance on instrument side: 54 mm [2.12 in] ■ Radial bonnet position ■ Integral flange mounting 	

Model overview for IV5 with gas metering pattern

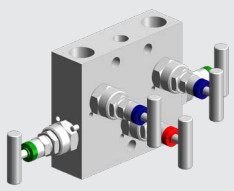
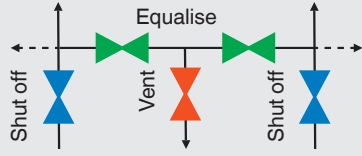
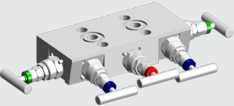
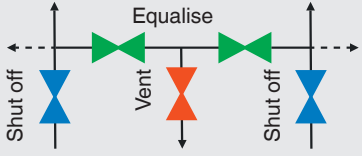
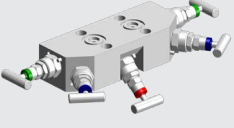
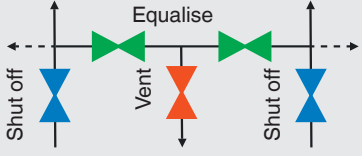
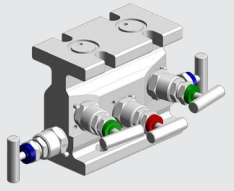
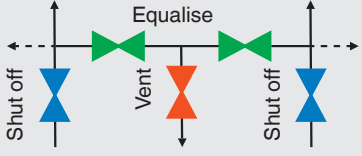
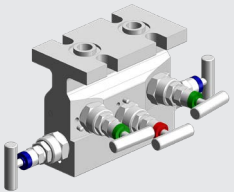
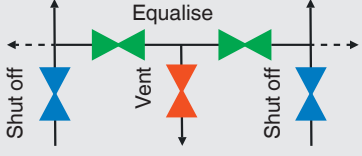
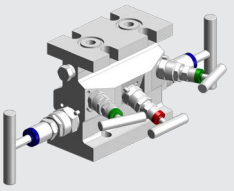
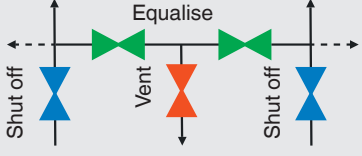
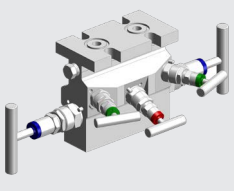
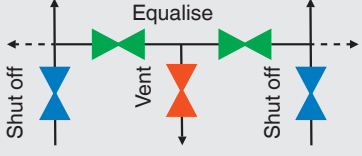
Model	Description	Functional diagram
	<ul style="list-style-type: none"> 5-valve manifold Centre distance on instrument side: 54 mm [2.12 in] Angled bonnet position 	
	<ul style="list-style-type: none"> 5-valve manifold Centre distance on instrument side: 54 mm [2.12 in] Centre distance on process side: 110 mm [4.33 in] Angled bonnet position Direct flange mounting 	
	<ul style="list-style-type: none"> 5-valve manifold Centre distance on instrument side: 54 mm [2.12 in] Radial bonnet position, vent valve under 45° Direct flange mounting 	
	<ul style="list-style-type: none"> 5-valve manifold Centre distance on instrument side: 54 mm [2.12 in] Angled bonnet position H-shaped design Direct flange mounting 	
	<ul style="list-style-type: none"> 5-valve manifold Centre distance on instrument side: 54 mm [2.12 in] Angled bonnet position T-shaped design Direct flange mounting 	
	<ul style="list-style-type: none"> 5-valve manifold Centre distance on instrument side: 54 mm [2.12 in] Angled bonnet position H-shaped design Direct flange mounting Soft-seat through-bore bonnets for natural gas 	
	<ul style="list-style-type: none"> 5-valve manifold Centre distance on instrument side: 54 mm [2.12 in] Angled bonnet position T-shaped design Direct flange mounting Soft-seat through-bore bonnets for natural gas 	

Specifications

Basic information	
Basic features	<ul style="list-style-type: none"> ■ Blow-out proof valve spindle ■ Non-rotating, low-wear spindle tip ■ Metal-to-metal back seat design
Special design features	<ul style="list-style-type: none"> ■ Without ■ For oxygen, oil- and grease-free ■ ASME B31.1, power piping (only available with graphite sealing packing) ■ Dielectric design ¹⁾ ■ Short process adapter, non-stabilised ¹⁾ ■ Long process adapter, stabilised ¹⁾
Centre distance on instrument side	<ul style="list-style-type: none"> ■ 37 mm [1.46 in] ■ 54 mm [2.12 in], standard pattern ■ 54 mm [2.12 in], gas metering pattern
Standards used	
Basic design	<ul style="list-style-type: none"> ■ MSS SP-99, valves for measuring instruments ■ MSS SP-105, instrument valves for code applications ■ ASME B16.34, valves – flanged, threaded and welding end ■ ASME B1.20.1, pipe threads, general purpose (inch) ■ ASME B31.3, process piping ■ ASME BPVC, section VIII, division 1
Special design	<ul style="list-style-type: none"> ■ Without ■ ISO 10497, API 6FA and API 607, type test for fire safety ■ TA-Luft (VDI 2440) and ISO 15848-1, type test for fugitive emissions
Tests	MSS SP-61, pressure testing of valves
Special tests	<ul style="list-style-type: none"> ■ Without ■ API 598, valve inspection and testing ■ ISO 5208, pressure testing of metallic valves with leakage rate A
Material requirements	NACE MR0175 / ISO 15156, use in H ₂ S-containing environments in oil and gas production
Special material requirements	<ul style="list-style-type: none"> ■ Without ■ NORSOK M-630, specification for use in pipelines (Norway)
Marking	MSS SP-25, standard marking system for valves
Mounting	<ul style="list-style-type: none"> ■ Without mounting holes ■ Suitable for mounting bracket, with mounting holes ²⁾

1) Only available for model IV52N

2) For available mounting brackets, see „Accessories“

Bonnet	
Bonnet position	<ul style="list-style-type: none"> ■ Angled ■ Angled, equalising valve under 45° ■ Angled, vent and equalising valves under 45° ■ Radial ■ Radial, equalising valve under 45° ■ Radial, vent valve under 45° ■ Radial, equalising valve under 90° ■ Side-by-side
Bonnet design	<ul style="list-style-type: none"> ■ Screwed bonnet, 4 mm [0.16 in] bore size ■ Bonnet with extended handle, 4 mm [0.16 in] bore size ■ Miniature bonnet, 4 mm [0.16 in] bore size ■ Cryogenic bonnet for medium temperatures to -196 °C [-320 °F], 4 mm [0.16 in] bore size ■ OS&Y bonnet, bolted, 8 mm [0.31 in] bore size ¹⁾ ■ Bolted bonnet, 8 mm [0.31 in] bore size ■ Soft-seat through-bore bonnet for natural gas, only for model IV52N <p>→ For bonnet design, see page 10</p>

Bonnet	
Bonnet variant	<ul style="list-style-type: none"> ■ Without ■ Anti-tamper for shut-off, pressure equalising and vent valve, padlock not included ■ Anti-tamper for shut-off, pressure equalising and vent valve, padlock included ■ Anti-tamper for pressure equalising and vent valve, padlock not included ■ Anti-tamper for pressure equalising and vent valve, padlock included ■ Anti-tamper for vent valve, padlock not included ■ Anti-tamper for vent valve, padlock included ■ Small T-handle ■ T-handle from stainless steel 316L (1.4404)

1) Type tested for fire safety per ISO 10497, API 6FA and API 607

Process connection / Instrument connection			
Standard	<ul style="list-style-type: none"> ■ Threaded connection per ANSI B1.20.1, code NPT ■ Threaded connection per ISO 228-1, code G ■ Swivel connection ■ Weld-in connection ■ Compression fitting ■ Flange connection per IEC 61518, Form A or Form B ¹⁾ ■ Special design for protective enclosures ■ 90° angle connections ■ Direct flange mounting 		
Size	<table border="0" style="width: 100%;"> <tr> <td style="width: 50%; vertical-align: top;"> <ul style="list-style-type: none"> ■ ¼ NPT ■ ⅜ NPT ■ ½ NPT ■ ¾ NPT </td> <td style="width: 50%; vertical-align: top;"> <ul style="list-style-type: none"> ■ G ¼ ■ G ⅜ ■ G ½ ■ G ¾ </td> </tr> </table>	<ul style="list-style-type: none"> ■ ¼ NPT ■ ⅜ NPT ■ ½ NPT ■ ¾ NPT 	<ul style="list-style-type: none"> ■ G ¼ ■ G ⅜ ■ G ½ ■ G ¾
<ul style="list-style-type: none"> ■ ¼ NPT ■ ⅜ NPT ■ ½ NPT ■ ¾ NPT 	<ul style="list-style-type: none"> ■ G ¼ ■ G ⅜ ■ G ½ ■ G ¾ 		
Vent connection	<ul style="list-style-type: none"> ■ ¼ NPT female, plug screw included ■ ½ NPT female, plug screw included ■ ¼ NPT female with installed bleeder screw ■ G ¼ female, plug screw included ■ G ½ female, plug screw included ■ ¼ NPT female, plug screw included and bleeder screw installed 		

1) Available threaded bolts for flange connections:
 - Carbon steel, 8.8, included in delivery, though not pre-fitted
 - Stainless steel, A4-70, see „Accessories“

Operating conditions	
Permissible operating pressure	<ul style="list-style-type: none"> ■ ≤ 3,000 psi or ≤ 206 bar ■ ≤ 6,000 psi or ≤ 420 bar ■ ≤ 10,000 psi or ≤ 690 bar ¹⁾
Pressure and temperature limits	<p>The limits for operating pressure and temperature depend on the version and the sealing material. → For diagram, see page 12</p>

1) Not available for flange connections. Only available with material of the sealing packing from PTFE, see page 12

Material	
Wetted parts	
Valve body, bonnet body	<ul style="list-style-type: none"> ■ Stainless steel 316/316L (1.4401/1.4404) ■ Stainless steel 321 (1.4541) ■ Monel 400 (2.4360) ■ Hastelloy C276 (2.4819) ■ Stainless steel 6Mo (1.4547) ■ Duplex F51 (1.4462) ■ Super Duplex F55 (1.4501) ■ Inconel 625 (2.4856) ■ Incoloy 825 (2.4858)
Spindle tip	<ul style="list-style-type: none"> ■ Stainless steel 316/316L (1.4401/1.4404) ■ Monel 400 (2.4360) ■ Hastelloy C276 (2.4819) ■ Duplex F51 (1.4462) ■ Inconel 625 (2.4856) ■ Hardfaced with Stellite 6
Sealing packing	<ul style="list-style-type: none"> ■ PTFE, temperature range: -55 ... +204 °C [-67 ... +400 °F] ■ Polar PTFE, temperature range: -70 ... +204 °C [-94 ... +400 °F] ■ Graphite, temperature range: -55 ... +500 °C [-67 ... +932 °F] ■ SIGRAFLEX® ZX graphite, nuclear quality, temperature range: -55 ... +500 °C [-67 ... +932 °F] ■ FKM ¹⁾, temperature range: -29 ... +180 °C [-20 ... +356 °F] ■ FKM AED ^{1) 2)}, temperature range: -46 ... +180 °C [-50 ... +356 °F] ■ RTFE ³⁾, temperature range: -55 ... +180 °C [-67 ... +356 °F]
Non-wetted parts	
Gland nut, valve spindle, sealing bush, locking nut, locking pin	Stainless steel
Handle	<ul style="list-style-type: none"> ■ Stainless steel 303 (1.4305) ■ Stainless steel 316/316L (1.4401/1.4404)

1) Only available for miniature bonnet

2) Anti-explosive decompression

3) Reinforced PTFE, material for optional certificate "Emission protection in accordance with TA-Luft (VDI 2440) and ISO 15848-1"

Bonnet design

Screwed bonnet

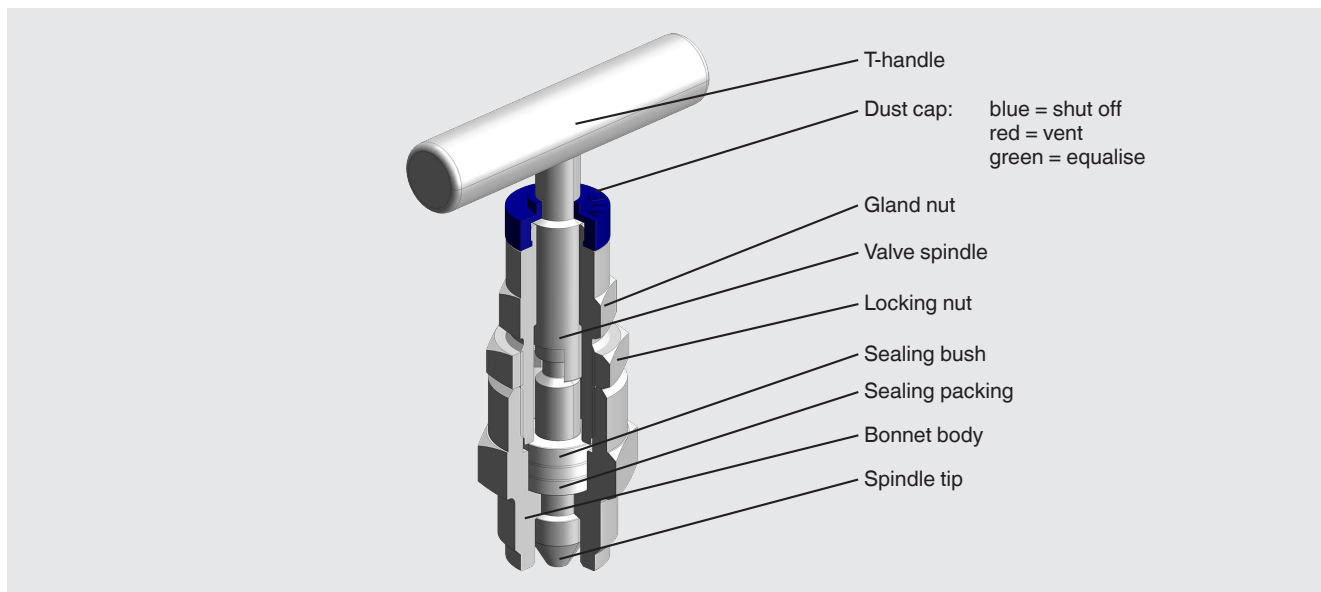

Bonnet with extended handle



Miniature bonnet



Cryogenic bonnet



OS&Y bonnet

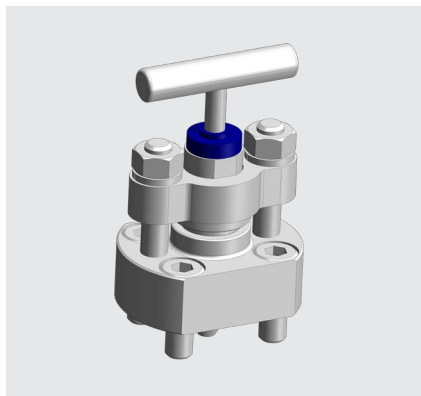

Bolted bonnet



Bonnet for panel mounting



**Soft-seat through-bore bonnet for natural gas,
only for model IV52N**

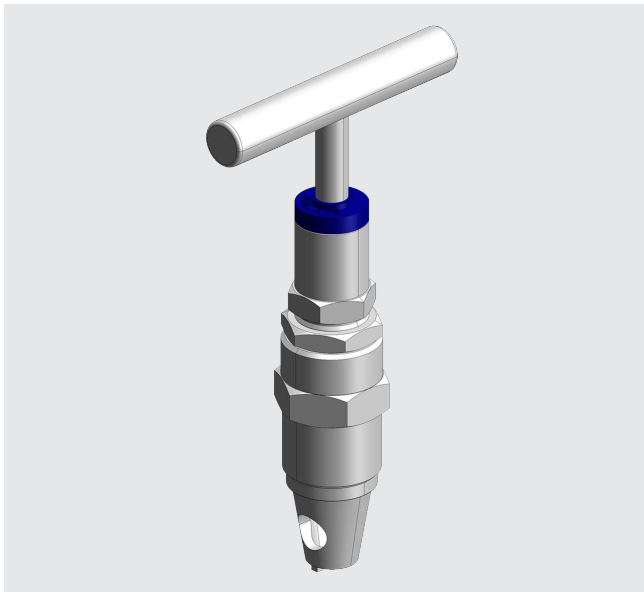

Bonnet variant

Anti-tamper variant

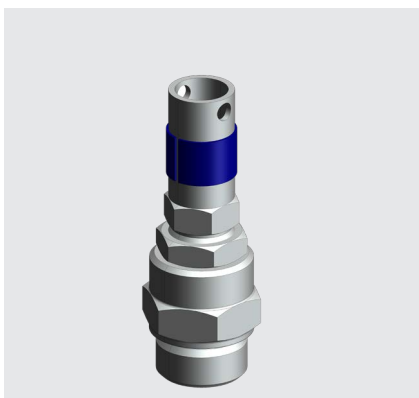

Anti-tamper variant with padlock

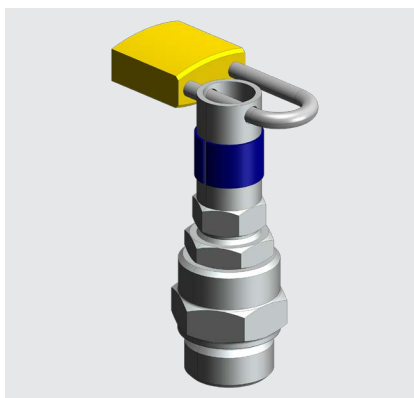

Accessory: Anti-tamper key



Order number: 81640006

The anti-tamper key is included in the scope of delivery for the anti-tamper variants.

Pressure-temperature diagram

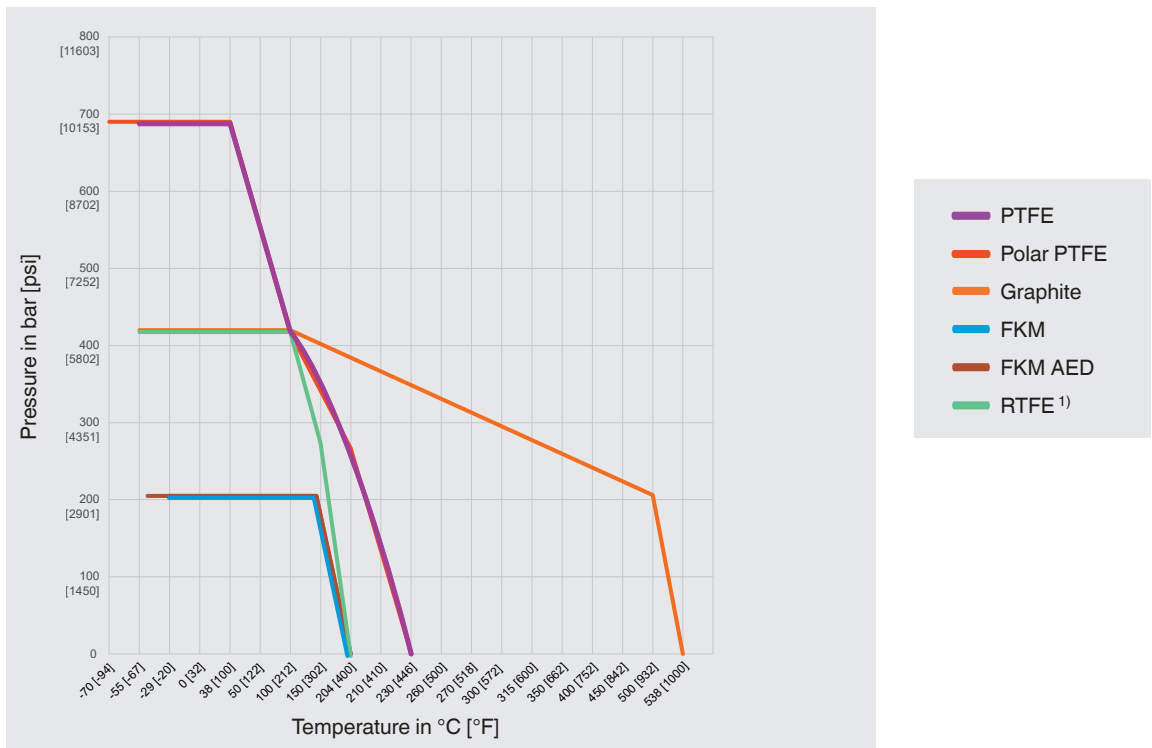

Sealing packing	Max. allowable operating pressure at defined temperatures			
	Minimum temperature	Temperature of 0 °C [32 °F]	Temperature of 20 °C [68 °F]	Maximum temperature
PTFE	690 bar at -55 °C	690 bar	690 bar	276 bar at 204 °C
	10,000 psi at -67 °F	10,000 psi	10,000 psi	4,000 psi at 400 °F
Polar PTFE	690 bar at -70 °C	690 bar	690 bar	276 bar at 204 °C
	10,000 psi at -94 °F	10,000 psi	10,000 psi	4,000 psi at 400 °F
Graphite or SIGRAFLEX® ZX graphite	420 bar at -55 °C	420 bar	420 bar	206 bar at 500 °C
	6,000 psi at -67 °F	6,000 psi	6,000 psi	2,987 psi at 932 °F
FKM	206 bar at -29 °C	206 bar	206 bar	206 bar at 180 °C
	2,987 psi at -20 °F	2,987 psi	2,987 psi	2,987 psi at 356 °F
FKM AED	206 bar at -46 °C	206 bar	206 bar	206 bar at 180 °C
	2,987 psi at -50 °F	2,987 psi	2,987 psi	2,987 psi at 356 °F
RTFE 1)	420 bar at -55 °C	420 bar	420 bar	276 bar at 180 °C
	6,000 psi at -67 °F	6,000 psi	6,000 psi	4,000 psi at 356 °F

1) Reinforced PTFE, material for optional certificate "Emission protection in accordance with TA-Luft (VDI 2440) and ISO 15848-1"

The table above provides information about the characteristics of the sealing at the respective process parameters. To maximise the service life, it is recommended that the valve should not be operated continuously at the temperature limits.

The minimum design temperature for most needle valves is -55 °C [-67 °F]. Some versions have other design temperatures due to material specifications.

For continuously low operating temperatures ≤ -55 °C [≤ -67 °F] a special polar design is needed.

Optional approvals

Logo	Description	Country
	EAC Pressure Equipment Directive	Eurasian Economic Community
-	Bureau Veritas Ships, shipbuilding (e.g. offshore)	International
-	CRN Safety (e.g. electr. safety, overpressure, ...)	Canada

Manufacturer's declaration

Logo	Description
-	Information on Pressure Equipment Directive (PED) Design, manufacturing and testing carried out in accordance with sound engineering practise
-	PMI ¹⁾ test certificate Valve body
-	Hydrogen for general use ²⁾ Suitable for general hydrogen applications under the following conditions: - Material proof for all wetted parts per MR0175 - Temperature range -55 ... +210 °C [-67 ... +410 °F] - Max. allowable operating pressure: 6,000 psi [420 bar] at 20 °C [68 °F] - With fugitive emission protection in accordance with TA-Luft (VDI 2440) and ISO 15848-1
-	Oil- and grease-free per ASTM G93-03 level C (< 66 mg/m²) - Sealing packing and lubricants in accordance with BAM requirements - Suitable for oxygen applications under the following temperature and pressure conditions (BAM): PTFE sealing packing: T ≤ 150 °C [302 °F] p ≤ 20 bar [290 psi] Graphite sealing packing: T ≤ 250 °C [482 °F] p ≤ 150 bar [2,175 psi]
-	Type tested for fire safety in accordance with API 607, ISO 10497, BS 6755-2 ³⁾
-	Suitability for drinking water per NSF/ANSI 61-G and NSF/ANSI 372
-	Fugitive emission protection in accordance with TA-Luft (VDI 2440) and ISO 15848-1 - Tightness class: AH - Endurance class: C01 - Temperature class: -29 ... +180 °C [-20 ... +356 °F]

1) Positive material identification

2) Please contact WIKA for hydrogen applications with different specifications

3) Only available for the OS&Y bonnet

Certificates (option)

Certificates	
Certificates	3.1 inspection certificate per EN 10204 - Material proof for all wetted parts per NACE MR0175 - Confirmation of pressure tests per MSS SP-61 ¹⁾ - Confirmation of pressure tests per API 598 or API 6D

1) The following tests are performed on 100 % of the valves:

- Valve shell test: 15 s test duration with 1.5 times the allowable working pressure

- Valve seat test: 15 s test duration with 1.1 times the allowable working pressure on the shut-off bonnets

Dimensions in mm [in]

The following dimensions are for versions made of stainless steel 316/316L (1.4401/1.4404). With other materials the dimensions and shape may change.

Model IV304

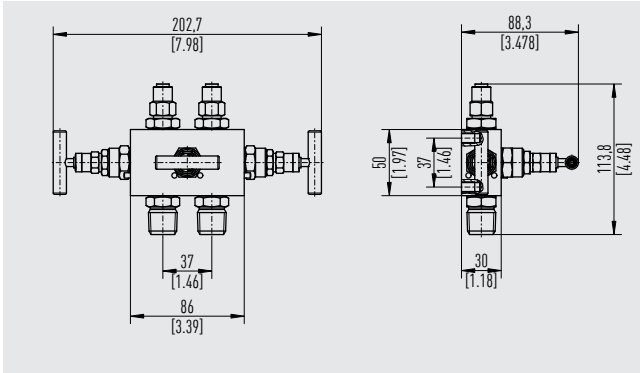

Model IV315

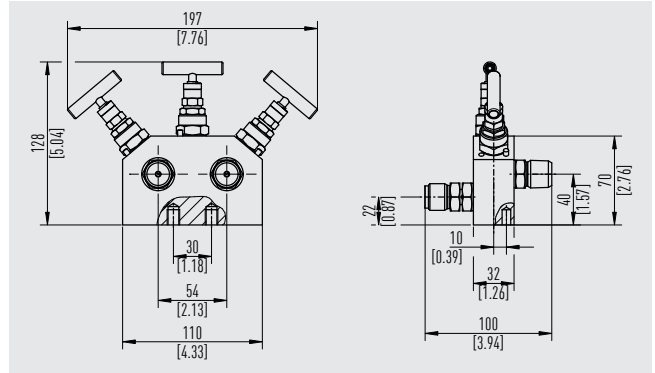

Model IV319

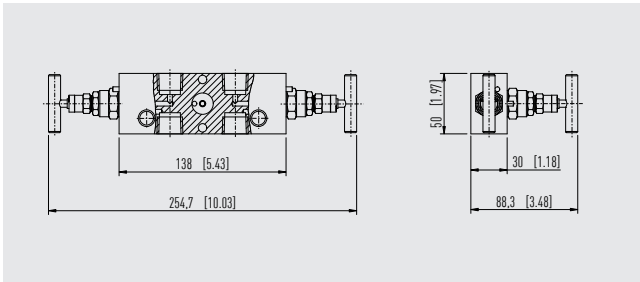

Model IV313

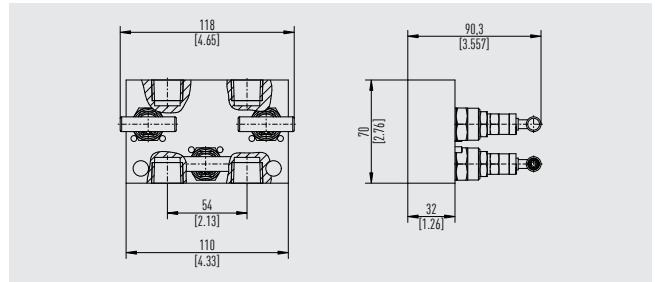

Model IV316

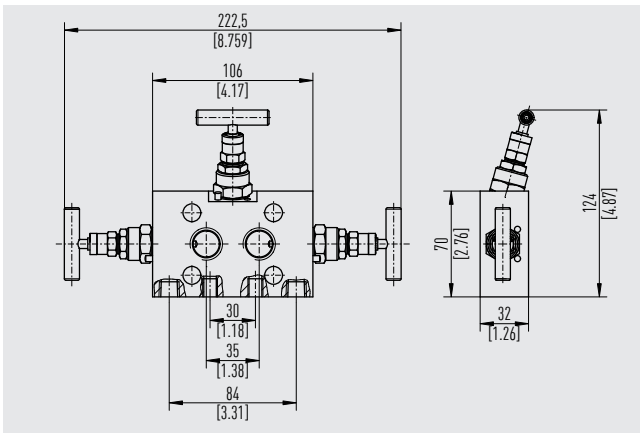

Model IV318

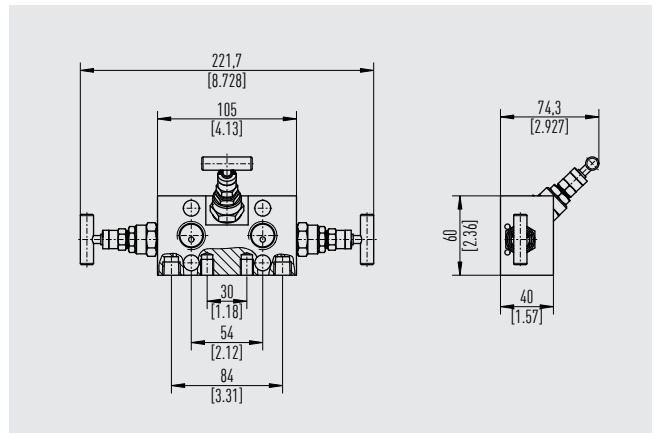

Model IV31V

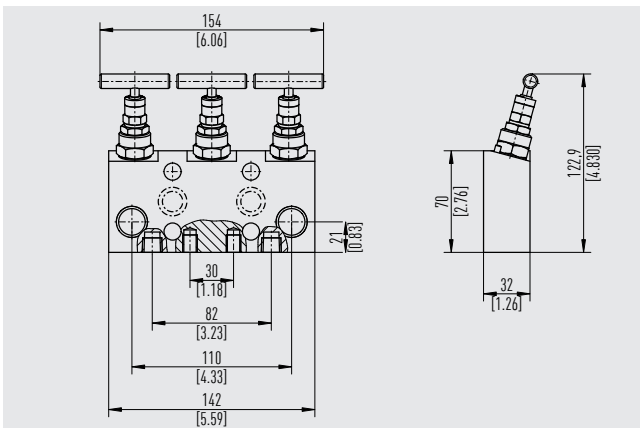

Model IV31E

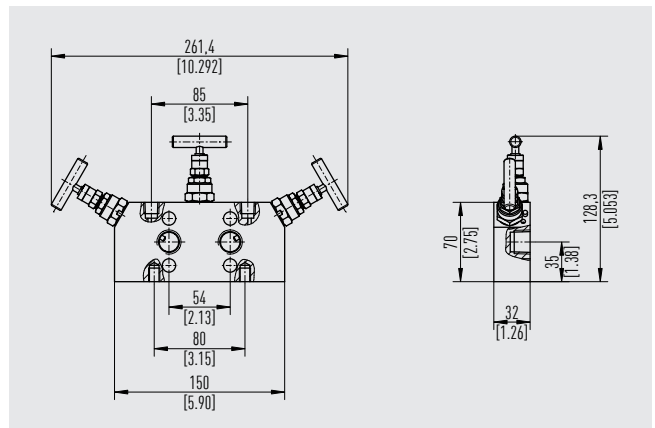

Model IV31H

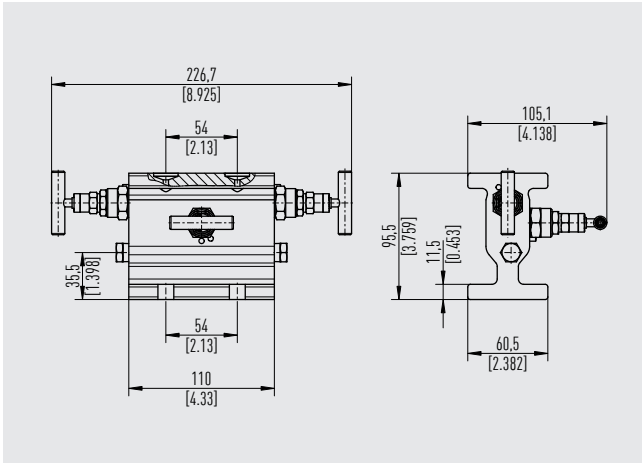

Model IV31T

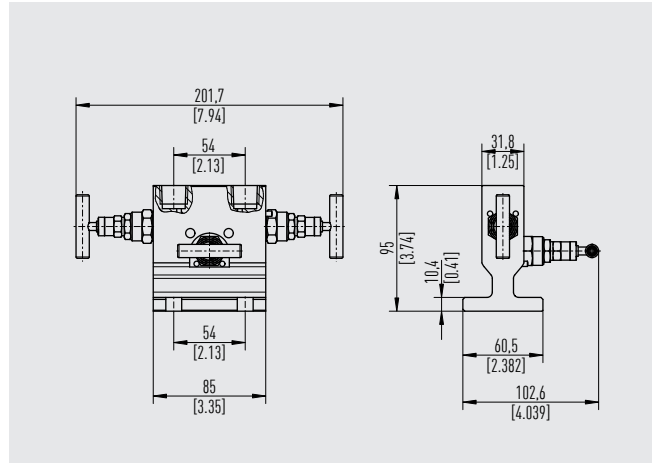

Model IV31D

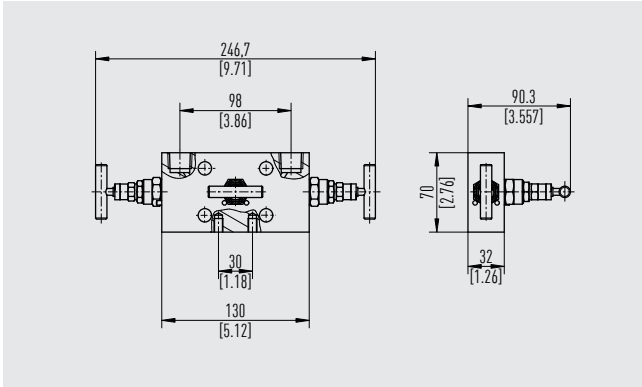

Model IV31S

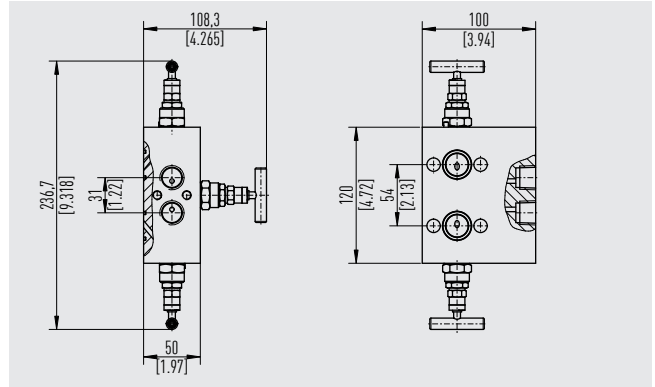

Model IV31R

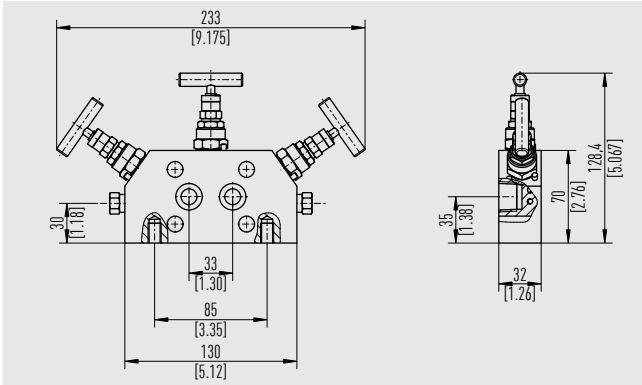

Model IV3D9

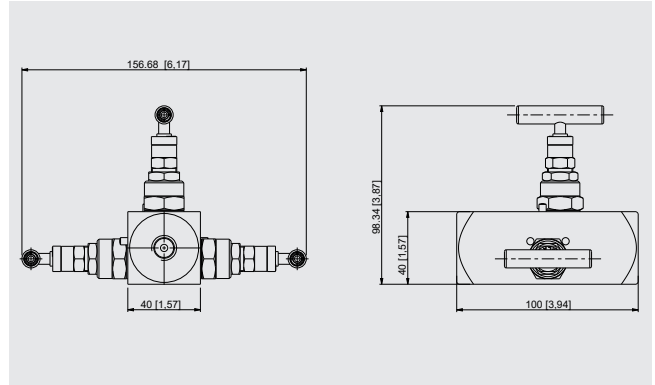

Model IV504

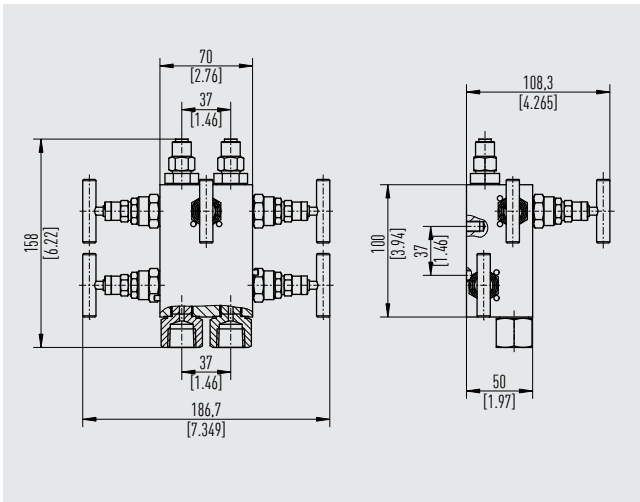

Model IV515

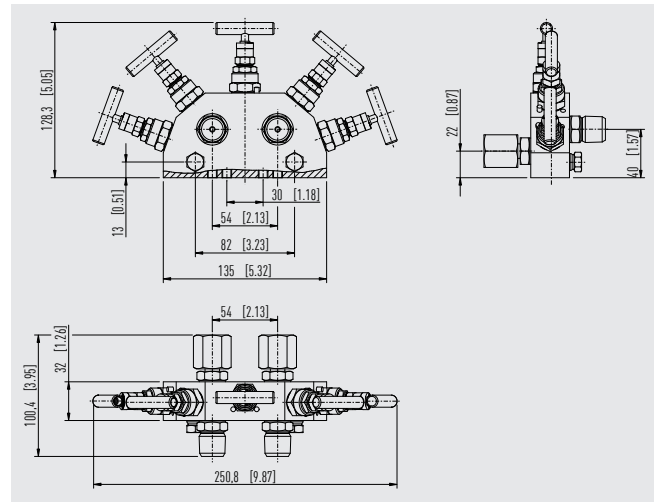

Model IV519

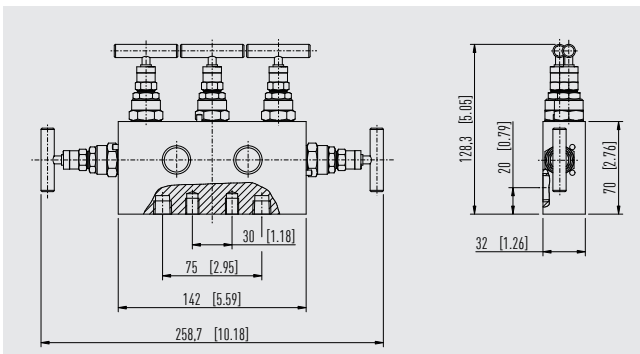

Model IV513

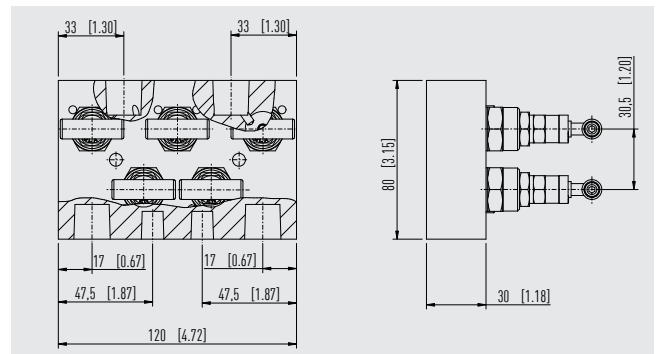

Model IV516

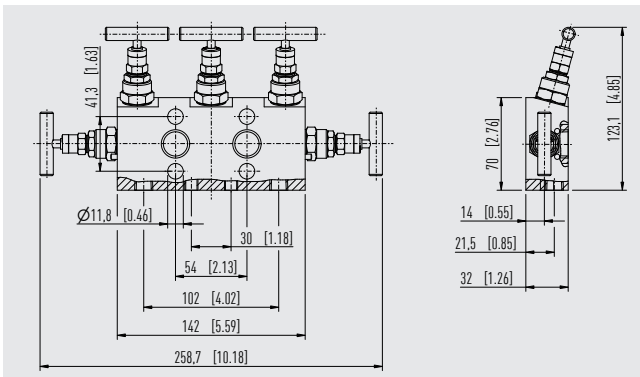

Model IV518

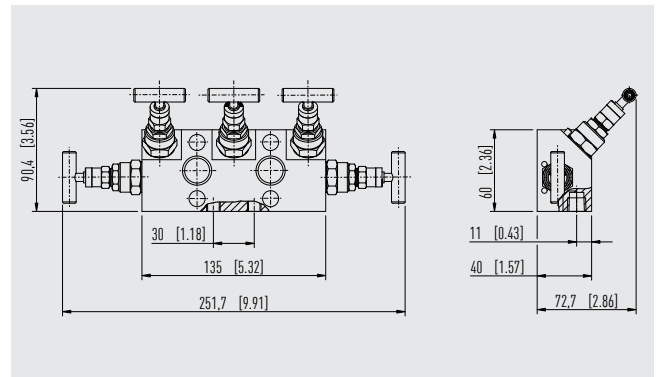

Model IV51V

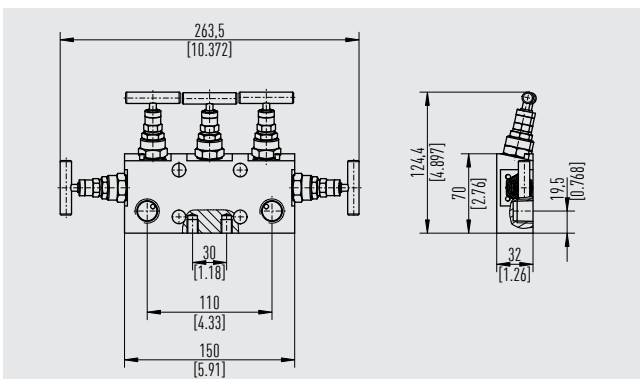

Model IV51E

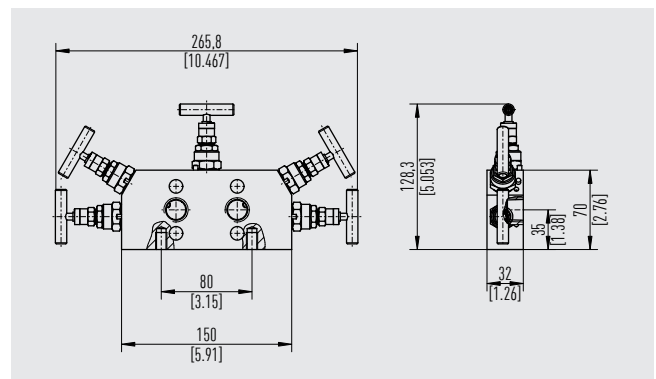

Model IV51G

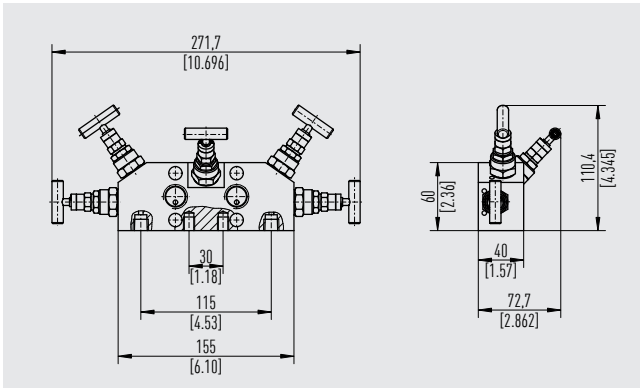

Model IV51H

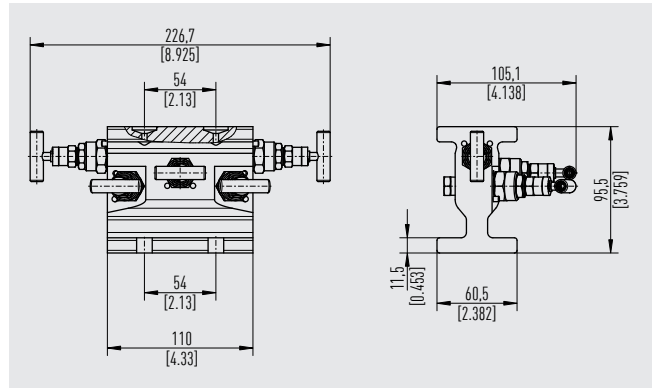

Model IV51T

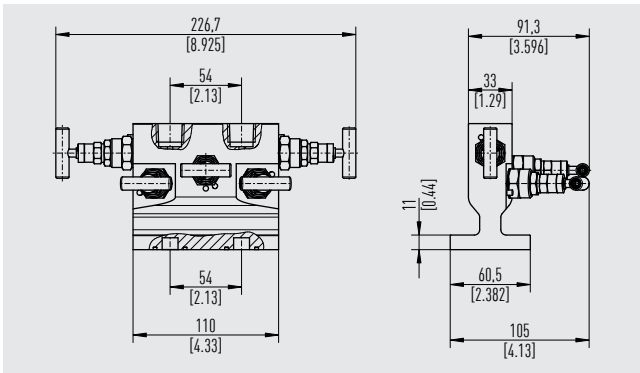

Model IV51D

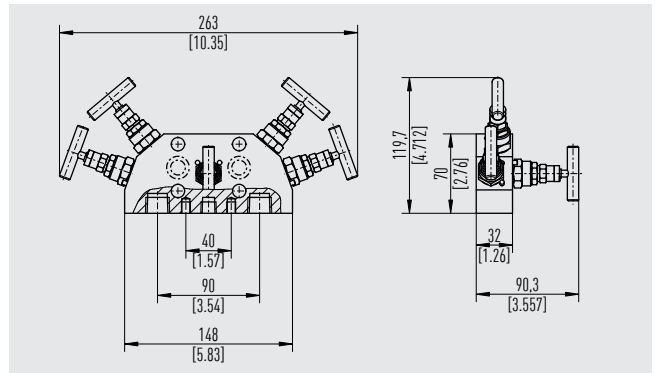

Model IV51S

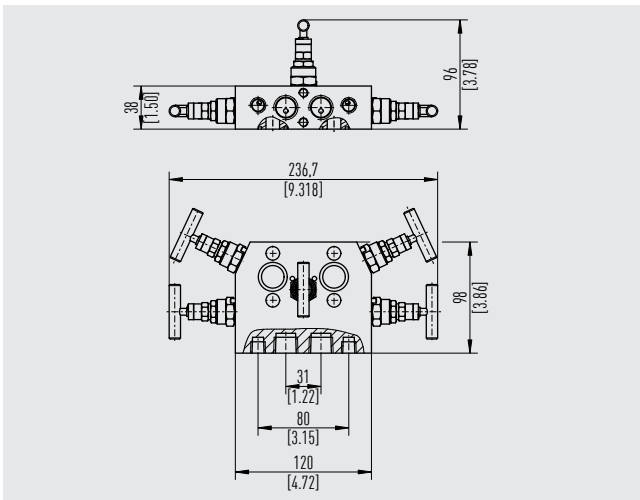

Model IV51R

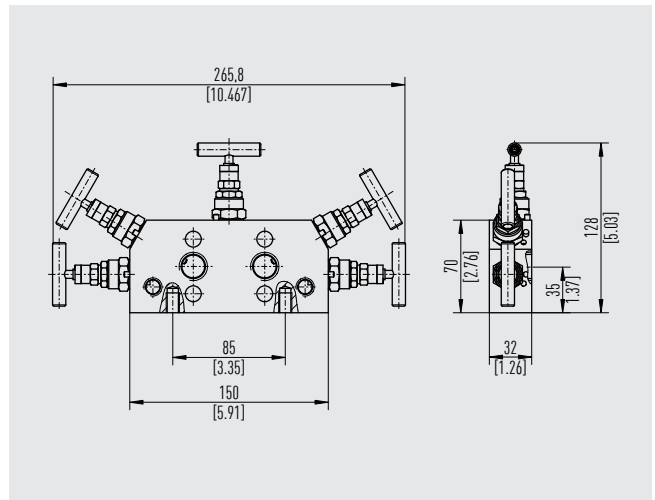

Model IV529

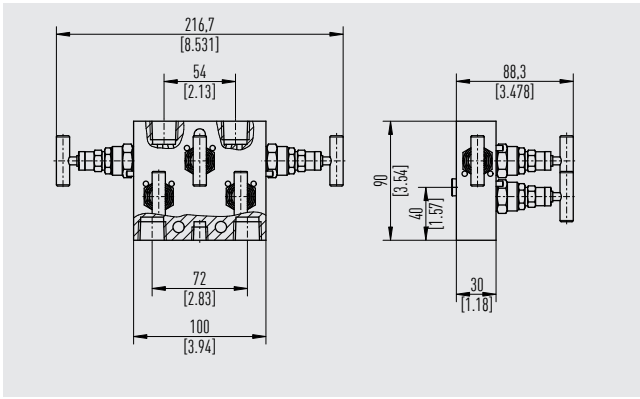

Model IV52V

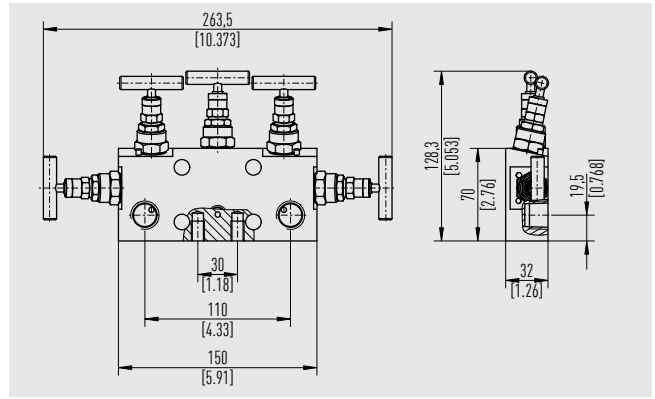

Model IV52G

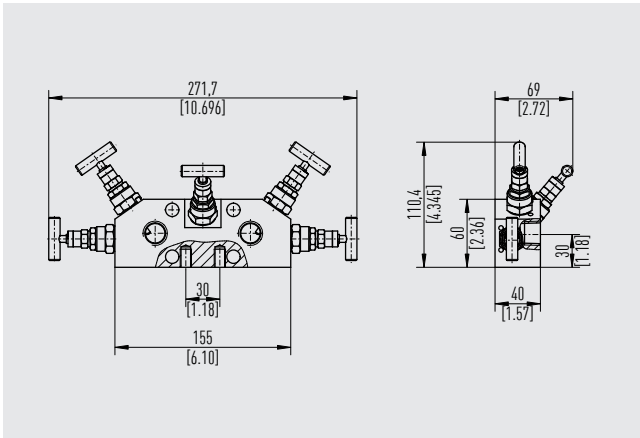

Model IV52H

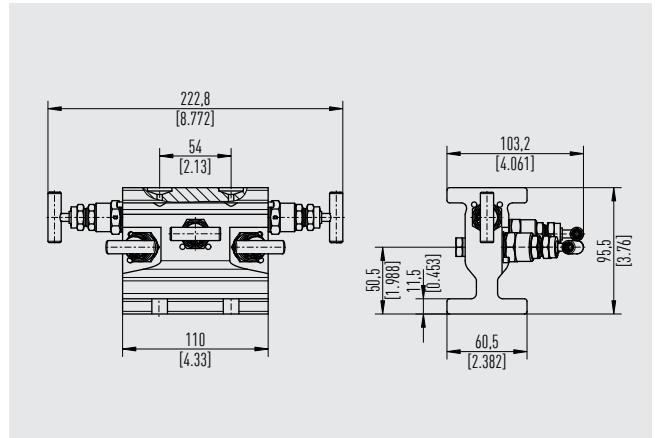

Model IV52T

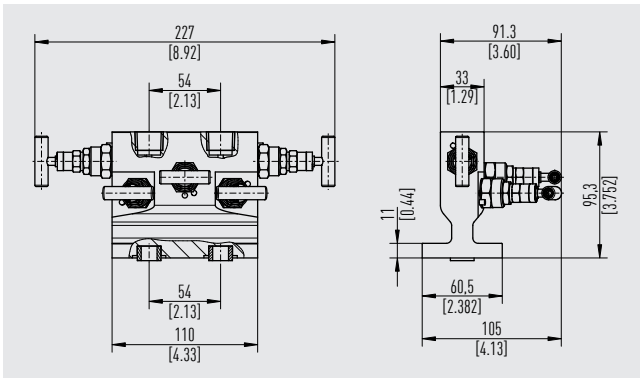

Model IV52N, H-shaped design

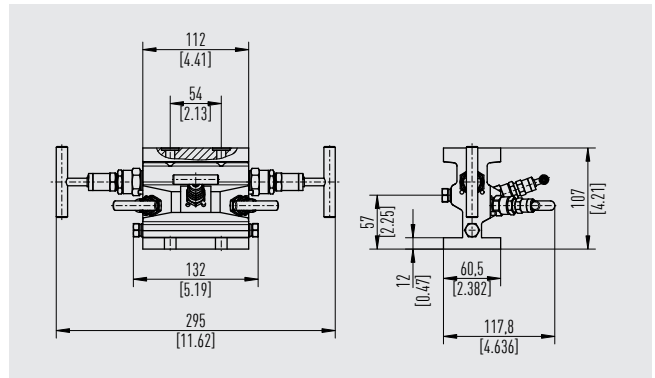

Model IV52N, T-shaped design

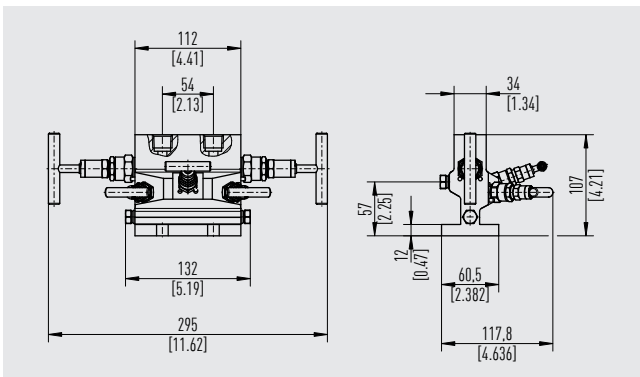

Accessories

Mounting kit is suitable for versions for mounting bracket, with mounting holes

Scope of delivery: mounting bracket, U-bolts, nuts, screws

Material: stainless steel 316L

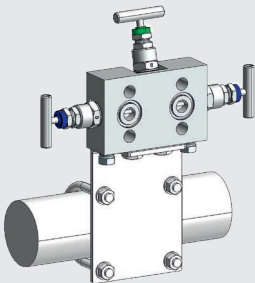
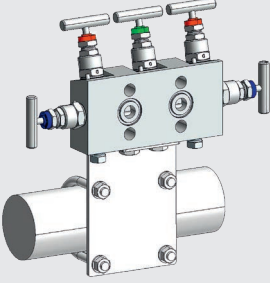
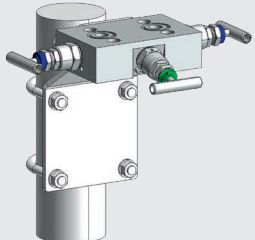
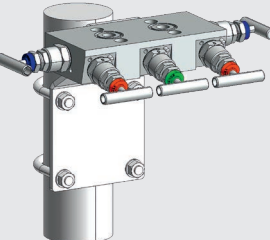
Mounting kit			
For models	Centre distance on instrument side	Pipe alignment (models shown are examples)	Order number
IV316, IV318, IV31V, IV516, IV518, IV519, IV51G, IV51V	54 mm [2.12 in]	 <p>Horizontal</p>  <p>Horizontal</p>	14267553
IV315, IV316, IV318, IV31V, IV516, IV518, IV519, IV51G, IV51V	54 mm [2.12 in]	 <p>Vertical</p>  <p>Vertical</p>	14289800
IV304, IV504	37 mm [1.46 in]	Horizontal or vertical	81509393
IV504	37 mm [1.46 in]	Vertical	14474946
IV31H, IV31T, IV52H, IV52T	54 mm [2.12 in]	Horizontal or vertical	81509385
IV51H, IV51T	54 mm [2.12 in]	Horizontal or vertical	81509391
IV31R, IV51R	54 mm [2.12 in]	Horizontal	81509395
IV319	54 mm [2.12 in]	Vertical	81653990
IV313	54 mm [2.12 in]	Vertical	81509384
IV31E, IV51E	54 mm [2.12 in]	Vertical	81647826
IV31R, IV51R	54 mm [2.12 in]	Vertical	81509387
IV515	54 mm [2.12 in]	Vertical	81509389
IV529	54 mm [2.12 in]	Vertical	81509396

Description	Order number
Anti-tamper key, stainless steel 303 (1.4305)	81640006
Adapter ½ NPT, female - ¾ NPT, male, stainless steel 316/316L (1.4401/1.4404)	81655622
Adapter ½ NPT, male - ¼ NPT; female, stainless steel 316/316L (1.4401/1.4404)	81655620
Bleeder screw ¼ NPT, stainless steel 316/316L (1.4401/1.4404)	81652317
Plug screw ½ NPT, stainless steel 316/316L (1.4401/1.4404)	81652353
Plug screw ¼ NPT, stainless steel 316/316L (1.4401/1.4404)	81652350
Plug screw G ¼, male, stainless steel 316/316L (1.4401/1.4404)	81652351
2 x PTFE seal for G ½	81657706
2 x PTFE seal for flange connection per IEC 61518, Form A	81657688
2 x PTFE seal for flange connection per IEC 61518, Form B	81657693
2 x Graphite seal for G ½	81657707
2 x Graphite seal for flange connection per IEC 61518, Form A	81657692
2 x Graphite seal for flange connection per IEC 61518, Form B	81657696
4 x threaded bolt 7/16" UNF - 1", stainless steel 316/316L (1.4401/1.4404)	81655985
4 x threaded bolt 7/16" UNF - 1 ¾", stainless steel 316/316L (1.4401/1.4404)	81655988
4 x threaded bolt 7/16" UNF - 2", stainless steel 316/316L (1.4401/1.4404)	81655982
4 x threaded bolt 7/16" UNF - 2 ¾", stainless steel 316/316L (1.4401/1.4404)	81655984
Adapter Minimes 1215 - ¼ NPT, male, carbon steel	81655625
Adapter Minimes 1620 - G ¼, male, stainless steel 316Ti (1.4571)	14503075
Swivel adapter ½ NPT, male - ½ NPT, female, max. pressure 10,000 psi [690 bar], stainless steel 316/316L (1.4401/1.4404)	81655619
Swivel adapter ½ NPT, male - G ½, female, with retaining ring, max. pressure 6,000 psi [420 bar], stainless steel 316/316L (1.4401/1.4404)	81655624
Swivel adapter G ¾ A, male - G ½ A, male, max. pressure 6,000 psi [420 bar], stainless steel 316/316L (1.4401/1.4404)	81655618
Swivel adapter G ¾ A, male - G ¼ A, male, max. pressure 6,000 psi [420 bar], stainless steel 316/316L (1.4401/1.4404)	81655617
Swivel adapter G ¾ A, male - G ½, female, with retaining ring, max. pressure 6,000 psi [420 bar], stainless steel 316/316L (1.4401/1.4404)	81655621
Swivel adapter G ½, male - G ½, female, with retaining ring, max. pressure 6,000 psi [420 bar], stainless steel 316/316L (1.4401/1.4404)	81655623
Adapter tube fitting 6 mm OD - ¼ NPT, male, stainless steel 316/316L (1.4401/1.4404)	81643499
Adapter tube fitting 10 mm OD - ¾ NPT, female, stainless steel 316/316L (1.4401/1.4404)	81643536
Adapter tube fitting 6 mm OD - ½ NPT, female, stainless steel 316/316L (1.4401/1.4404)	81643562
Adapter tube fitting 12 mm OD - ¾ NPT, male, stainless steel 316/316L (1.4401/1.4404)	81643526

→ Other accessories on request

Ordering information

Model / Bonnet design / Bonnet variant / Sealing packing /
Special design feature / Options

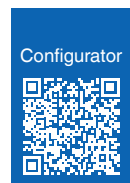

© 02/2018 WIKA Alexander Wiegand SE & Co. KG, all rights reserved.
The specifications given in this document represent the state of engineering at the time of publishing.
We reserve the right to make modifications to the specifications and materials.
In case of a different interpretation of the translated and the English data sheet, the English wording shall prevail.

