

Pressure
Temperature
Level
Flow
Calibration

Chemical and petrochemical industries



WIKAI

Part of your business

About us



**Alexander Wiegand,
Chairman and CEO WIKA**

As a family-run business acting globally, with over 8,500 highly qualified employees, the WIKA group of companies is a worldwide leader in pressure and temperature measurement. The company also sets the standard in the measurement of level and flow, and in calibration technology.

Founded in 1946, WIKA is today a strong and reliable partner for all the requirements of industrial measurement technology, thanks to a broad portfolio of high-precision instruments and comprehensive services.

With manufacturing locations around the globe, WIKA ensures flexibility and the highest delivery performance. Every year, over 50 million quality products, both standard and customer-specific solutions, are delivered in batches of 1 to over 10,000 units.

With numerous wholly-owned subsidiaries and partners, WIKA competently and reliably supports its customers worldwide. Our experienced engineers and sales experts are your competent and dependable contacts locally.

Contents

| | |
|--|-----------|
| Instrument requirements | 4 |
| Certificates and approvals | 4 |
| Materials | 5 |
| Explosion-protected areas | 6 |
| Functional safety | 8 |
| Electrical output signals | 10 |
| Welding processes | 11 |
| Adaptation to the process with diaphragm seals | 12 |
| Pressure measurement | 14 |
| Temperature measurement | 26 |
| Level measurement | 40 |
| Flow measurement | 42 |
| Calibration technology and services | 46 |

WIKA – Your partner in the chemical and petrochemical industries

The chemical and petrochemical industries make extremely high demands on all instruments used within the process. They are subject to strict international guidelines like the PED and ATEX. Electronic, mechatronic and mechanical measuring instruments for pressure, temperature and level are used for general applications as well as in potentially explosive areas, and must operate as satisfactorily in aggressive environments as in non-aggressive environments.

You will find a large selection of pressure and temperature and level measuring instruments to suit your specific requirements. Individually tailored advice and proposals, to match solutions to your needs, supplement our extensive offering of products and services. Our expertise and dependability, in addition to our worldwide sales and service network, has made WIKA a global contracting partner with many well-known names in the international chemical and petrochemical industries.

Certificates and approvals

Given the increasing demands in terms of quality and product safety of chemical products, certified measuring instruments for pressure, temperature and level contribute considerably to

the safety of the production processes. Therefore WIKA offers a wide range of approvals and certificates.

Pressure equipment directive 97/23/EC

The European pressure equipment directive 97/23/EC has to be applied to almost all mechanical and electrical pressure measuring instruments, throughout the European Union. WIKA instruments are certified by TÜV SÜD Industrieservice GmbH, Germany.

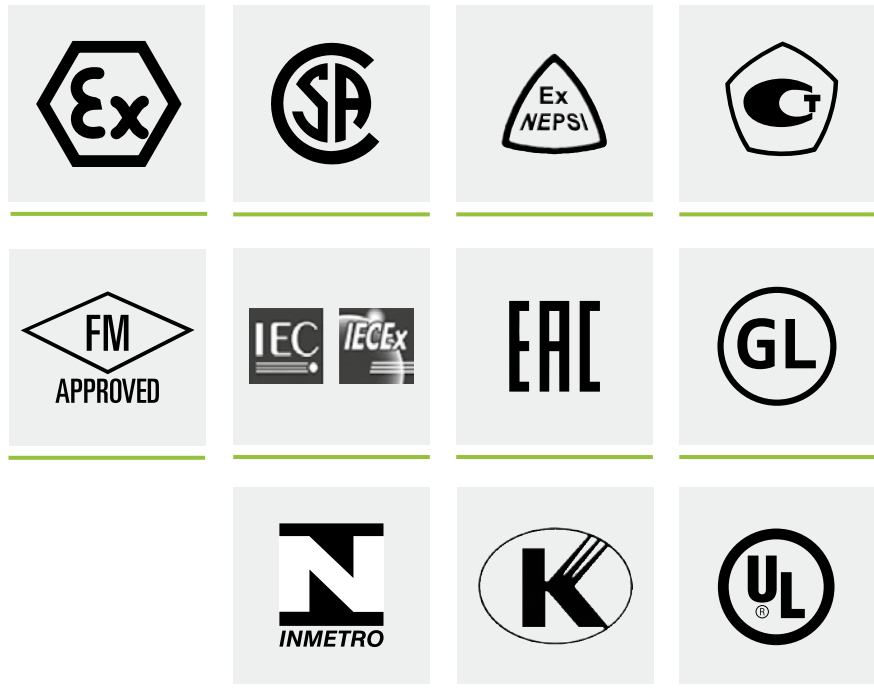

Materials

Stainless steels are the main standard material in chemical process technology. The worldwide commonly used materials 316L and 1.4404/1.4435 are generally employed.

For high-pressure measurement, high-strength stainless steel is used, while for pressure measurements at elevated temperatures, temperature resistant stainless steel is needed. For chemical processes involving highly-aggressive media, – in combination with diaphragm seals/gauges with diaphragm or capsule for pressure measurement, or thermowells for temperature measurement - an extensive range of chemically-resistant materials is available. In this case, all wetted parts are made of this special material.

Diaphragm seals are manufactured from 316L stainless steel (1.4404/1.4435) as a standard. If diaphragm seals are required with wetted parts in special metals, then these are „metallically bonded“ using one of WIKA's patented procedures. The junction between the diaphragm and the diaphragm seal body is designed to be diffusion-tight, vacuum protected and tear-resistant, and also resistant to all extremes of temperature to which the diaphragm seal might be exposed.



With gauge, absolute and differential pressure measuring instruments using diaphragm elements, wetted parts can be manufactured in the widest range of special materials. Measuring systems for Bourdon tube instruments are manufactured in 316L stainless steel (1.4404) as standard. In addition WIKA offers materials per EN ISO 15156-3/NACE MR 0175 and NACE MR 0103 for use in the petrochemical industry.

All pressure-bearing materials used can be supplied with a 3.1 traceability certificate.

| Material | Unified numbering system (UNS) |
|--|--------------------------------|
| Stainless steels | |
| Stainless steel 1.4404 (316L) | S31603 |
| Stainless steel 1.4435 (316L) | S31603 |
| Stainless steel 1.4539 (904L) | N08904 |
| Stainless steel 1.4541 (321) | S32100 |
| Stainless steel 1.4571 (316Ti) | S31635 |
| Stainless steel 1.4304 (304L) | S30403 |
| Stainless steel 1.4466 (urea grade) | S31050 |
| Stainless steel 1.4542 (630) | S17400 |
| Duplex 2205 1.4462 | S31803 |
| Superduplex 1.4410 | S32750 |
| Coatings | |
| Stainless steel with ECTFE coating | |
| Stainless steel with PFA coating | |
| Stainless steel with gold plating 25µm | |
| Stainless steel with PTFE foil | |
| Stainless steel with Wikaramic® | |

| Material | Unified numbering system (UNS) |
|---------------------------|--------------------------------|
| Other materials | |
| Tantalum | R05200 |
| Hastelloy C276 2.4819 | N10276 |
| Hastelloy C22 2.4602 | N06022 |
| Inconel 600 2.4816 | N06600 |
| Incoloy 825 2.4858 | N08825 |
| Inconel 625 2.4856 | N06625 |
| Monel 400 2.4360 | 04400 |
| Nickel | N02200 |
| Titanium 3.7035 (grade 2) | R50400 |
| Titanium 3.7235 (grade 7) | R52400 |

Other materials on request

Use in explosion-protected areas

Explosion protection is a section of technology, which deals with the protection from the occurrence of explosions and with their effects. It serves the avoidance of damage to persons or objects caused by technical products, plants and

other equipment. Explosion protection comprises technical solutions, such as ignition protection types, and legal provisions, such as the ATEX directives of the European Union.

Zone classification

The operator/employer is obligated, independent of the size of his business, to evaluate all areas of his business according to potentially explosive zones and state this in the explosion protection document.

The zones are categorised according to the probability of the occurrence of a potentially explosive atmosphere.

Conditions in the hazardous area

| Material groups | Temporary behaviour of the flammable material in the hazardous area | Classification of hazardous areas | | | | | | |
|-----------------|---|-----------------------------------|------|-----------------------------|-------|----------|--------------------------|-------------------|
| | | IEC | EPL* | EU directive 94/9/EC (ATEX) | | | US NEC 500 Canada CEC | US NEC 505 |
| | | | | Zone | Group | Category | | |
| Gases, vapours | Are present continuously, for long periods or frequently | Zone 0 | Ga | Zone 0 | II | 1 G | Class I Division 1 | Class I Zone 0 |
| | Occur occasionally | Zone 1 | Gb | Zone 1 | II | 2 G | | Class I Zone 1 |
| | Probably do not occur at all, but if they do, only rarely or for short periods | Zone 2 | Gc | Zone 2 | II | 3 G | Class I Division 2 | Class I Zone 2 |
| Dust | Are present continuously, for long periods or frequently | Zone 20 | Da | Zone 20 | II | 1 D | Class II | -- |
| | Occur occasionally | Zone 21 | Db | Zone 21 | II | 2 D | Division 1 | -- |
| | Probably do not occur at all, due to suspended dust, but if they do, only rarely or for short periods | Zone 22 | Dc | Zone 22 | II | 3 D | Class II Division 2 | -- |
| Methane, dust | Hazardous areas | -- | Ma | -- | I | M1 | -- | -- |
| | Potentially hazardous areas | -- | Mb | -- | I | M2 | -- | -- |
| Fibres/flyings | | -- | | -- | -- | -- | Class III | -- |

*) Equipment protection level per IEC 2007 and CENELEC 2009

ATEX product directive 94/9/EC

The name ATEX (from the French "Atmosphère explosible") is used as a synonym for the two European Community directives covering the subject of explosion protection; the product directive 94/9/EC and the operating directive 1999/92/EC.

This directive also includes non-electrical instruments for the first time, since purely mechanical pressure gauges can also present an ignition risk through inadmissibly high heating. The purpose of the directive is to protect people who work within hazardous areas. Appendix II of the directive contains the fundamental health and safety requirements to be considered by the manufacturer and to be verified by appropriate conformity assessment procedures.

Equipment groups

- Equipment group I (equipment for use in above-ground or underground areas of mines)
- Equipment group II (equipment for use within all other areas)

Category

- Category 1 (very high safety)
- Category 2 (high safety)
- Category 3 (safety in normal operation)

Instruments of a certain category may be used only for certain zones. E.g. instruments of category 2 only for zones 1 and 2 (with gas or vapours) and/or for zones 21 and 22 (for dusts).

Ignition protection types (examples)

| Ignition protection type | Marking | Definition | IEC | ATEX approval | FM/UL |
|------------------------------|---------|--|--------------|---------------|------------------------------|
| Flameproof enclosure | Ex d | Propagation of an explosion to the outside is prevented. | IEC 60079-1 | EN 60079-1 | FM 3615 UL 1203 |
| Intrinsic safety | Ex i | Limitation of the energy of sparks and temperatures | IEC 60079-11 | EN 60079-11 | FM 3610 UL 913 |
| Ignition protection type "n" | Ex n | Different protection principles only for zone II/div. 2 | IEC 60079-15 | EN 60079-15 | FM 3611 ANSI/ISA 12.12.01 |

Explosion group

Gases and vapours are divided into three explosion groups (IIA, IIB and IIC) according to their individual inflammability. So the degree of risk increases from explosion group IIA to IIC.

(The higher explosion group, e.g. IIC, in each case covers the lower ones, e.g. IIA and IIB).

Groups

| IEC/ATEX/NEC 505 | | NEC 500/CEC | |
|------------------|-----------------------|----------------------------|-------------------|
| Gas groups | | | |
| Group I | | Class I | |
| I | Methane | --* | --* |
| Group II | | Class I | |
| IIA | Propane | Propane | Class I, group D |
| IIB | Ethylene | Ethylene | Class I, group C |
| IIB + H2 | Ethylene + hydrogen | Acetylene | Class I, group B |
| IIC | Acetylene Hydrogen | Hydrogen | Class I, group A |
| Dust groups | | | |
| Group III** | | Class II/Class III | |
| IIIA | Flammable flakes | Fibres, flyings | Class III |
| IIIB | Non-conducting dust | Non-carbon-containing dust | Class II, group G |
| IIIC | Conducting dust | Carbon-containing dust | Class II, group F |
| | -- | Metal dust | Class II, group E |

* does not fall under the scope of NEC or CEC

** per IEC 2007 and CENELEC 2009

Temperature classes

In order to make the project engineering of installations easier, six temperature classes (T1 to T6) for permissible surface temperatures were specified. Depending on their individual ignition temperatures, inflammable gases and

vapours are assigned a particular temperature class. A higher temperature class also covers lower temperature classes.

Temperature classes and maximum surface temperatures

| Class | T1 | T2 | T2A, T2B, T2C, T2D | T3 | T3A, T3B, T3C | T4 | T4A | T5 | T6 |
|------------------|--------|--------|--------------------------------------|--------|----------------------------|--------|--------|--------|-------|
| IEC/ATEX/NEC 505 | 450 °C | 300 °C | -- | 200 °C | -- | 135 °C | -- | 100 °C | 85 °C |
| NEC 500/CEC | 450 °C | 300 °C | 280 °C 260 °C 230 °C 215 °C | 200 °C | 180 °C 165 °C 160 °C | 135 °C | 120 °C | 100 °C | 85 °C |

Functional safety

Using components of excellent quality is a prerequisite for preventing risks to persons, the environment and property. Reliable components in control and instrumentation technology (C&I) safeguard critical processes in the chemical and petrochemical industries. In this connection one is generally speaking about circuit breakers, safety circuits or safety functions.

The required safety-relevant characteristics of the components used are currently specified through, for example, the IEC 61508 (functional safety - general) and IEC 61511 (functional safety in the process industry) standards. Here, amongst other things, the term Safety Integrity Level (SIL) is defined. The failure rates of a component are determined by the manufacturer and made available to the user.

An essential tool in this context is FMEDA (Failure Modes, Effects and Diagnostic Analysis). With this, the statistical values of individual components and their functional correlations are jointly assessed. The results are quantified data on the probability of failure and the reliability of the components.



Model T32



Model IPT-10

Safety-related values

IEC 61508 applies to all applications of electronic systems whose malfunction could have a massive influence on the safety of persons, the environment and equipment. The safety-related requirement is calculated in accordance with the probability of occurrence of a damaging event and its potential impact.

The higher the expected extent of the damage and its probability of occurrence, the higher the classification from SIL 1 to SIL 4 is set.

This classification is made by the plant operator, using a 'risk graph'. In accordance with IEC 61508, the entire safety circuit, i.e. all components used in the circuit (sensors, logic processors, actuators) must be considered.

In order that such a calculation and risk assessment can be carried out, a knowledge of the construction of each individual component is needed.

The following instruments are classified in accordance with IEC 61508/IEC 61511:

- Pressure transmitter IS-20
- Process transmitter IPT
- Temperature transmitter T32 and selected thermometers in combination with this transmitter
- Mechanical pressure switches
- Mechanical temperature switches



Model IS-3



Model PCS



Electrical output signals

Bus technology

The general trend towards using digital bus systems instead of the conventional field instruments with an analogue output signal is being seen in the chemical industry as well.

Advantages:

- Higher accuracy
- Reduced wiring requirements
- Possibility of parameterisation
- Extended diagnostics of field instruments
- Improved process monitoring
- Reliable digital signal transmission

To plant managers this means a cost reduction and an increased availability of their plants.

Standard output signals

Based on the variety of output signals available our measuring instruments can be easily integrated into any plant concept. Among others, the following standard output signals are available:

- Analogue (e.g. 4 ... 20 mA, 0 ... 10 V)
- 4 ... 20 mA with a superimposed HART® protocol
- PROFIBUS® PA
- FOUNDATION™ Fieldbus

Interoperability

Internal and also external tests certify the compatibility of our transmitters with almost all open software and hardware tools.



For safety, the best weld

Pressure and temperature measuring instruments

WIKA is certified as a manufacturer of pressure and temperature measuring instruments in accordance with the AD-2000/HP0 requirements, DIN EN ISO 3834-2 and DIN 2303. Apart from standard TIG hand-welding, we also employ orbital welding, partly mechanised and fully mechanised TIG welding, resistance welding and laser welding. For pressure-bearing welded seams, numerous welding procedure tests are available. Austenitic stainless steel as well as nickel-based alloys (e.g. Monel 400 / 2.4360 / UNS N04400) are used.

As non-destructive test methods, WIKA offers helium leak tests, liquid penetrant inspections, ultrasonic testing and visual inspections. Test personnel are trained in accordance with DIN EN ISO 9712, so that recorded tests can be offered on request. Positive material identification (PMI) by means of optical emission spectroscopy and X-ray fluorescence techniques is available. Further investigations (e.g. X-ray inspection) are carried out by accredited external laboratories in accordance with DIN ISO IEC 17025.

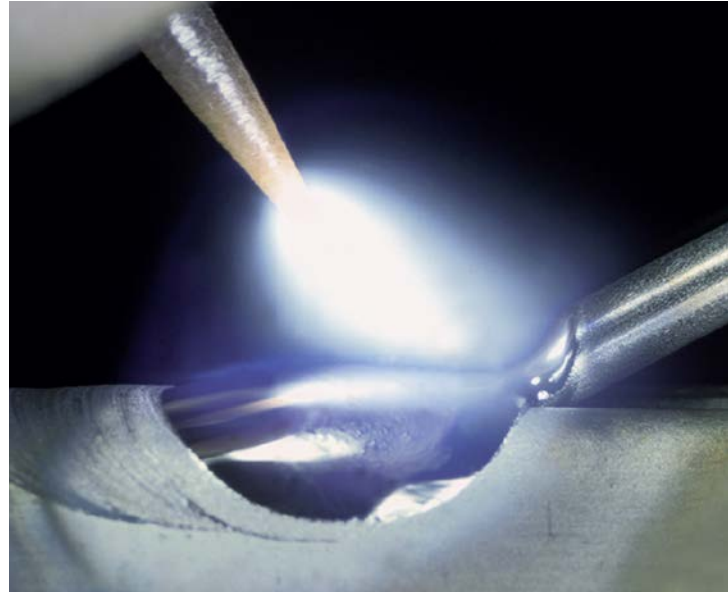

Non-destructive tests NDE/NDT

The most common non-destructive tests for thermowells are the pressure test, the liquid penetrant inspection and the PMI test.

■ Hydrostatic pressure test

This test is carried out using external pressure on flanged thermowells, and using an internal pressure test for welded or threaded thermowells. The level of the test pressure is determined according to the construction of the thermowell and the flange used. Common pressures used are between 60 and 500 bar (1.5 times the flange pressure rating) for between 3 and 15 minutes.

■ Liquid penetrant inspection

This testing is used, in particular, to examine the weld seams for defects. In this process the thermowell is wetted with a low viscosity indicator, which infiltrates any possible cracks which exist through the capillary effect. After the thermowell surface has been cleaned thoroughly, defects are made visible under UV light or by a developer.

■ Positive material identification test (PMI)

The PMI (positive material identification) test proves which alloy constituents exist in the material. There are various common test procedures. With spectrographic analysis an arc is generated between the thermowell surface and the test equipment, and the spectrum of this arc enables the alloy's elements to be identified – both qualitatively and quantitatively. This process does leave a characteristic burn mark on the workpiece. A test procedure which doesn't damage the surface is X-ray analysis; during the X-ray the atoms of the thermowell material are energised until they radiate themselves. The wavelength and intensity of the emitted radiation is in turn a measure of the alloy's constituent elements and their concentration.

Adaptation to the process with diaphragm seals

By using diaphragm seals, pressure measuring instruments can be adapted to even the harshest of conditions within process industries. A diaphragm made of the appropriate material separates the medium to be measured from the measuring instrument.

The internal space between the diaphragm and the pressure measuring instrument is completely filled with a system fill fluid. The process pressure is transmitted by the elastic diaphragm into the fluid and from there to the measuring instrument.

The instrument is connected to the diaphragm seal via a cooling element, a capillary or directly. By connecting the measuring instrument via diaphragm seals even the most difficult measuring requirements can be met:

- Use at extreme temperatures or temperature fluctuations
- Measurements in aggressive, corrosive, highly viscous, heterogeneous, crystallising media
- Process connection which is either free of dead spaces or where dead spaces are reduced
- Hygienic connection to the process
- Integration of pressure and temperature measurement into one measuring point
- Additional safety barrier for explosive or toxic media

Differential pressure transmitter DPT-10 with capillaries and diaphragm seals



System fill fluids

WIKA offers a broad range of system fill fluids between the diaphragm seal and the measuring instrument for a wide variety of applications.

For each application specially selected fluids are available.

| Name | Identification number KN | Solidification point °C | Boiling/ degradation point °C | Density at temperature 25 °C g/cm ³ | Kin. viscosity at temperature 25 °C cSt | Notes |
|----------------------------------|-----------------------------|----------------------------|-------------------------------------|--|---|--|
| Silicone oil | 2 | -45 | +300 | 0.96 | 54.5 | Standard |
| Glycerine | 7 | -35 | +240 | 1.26 | 759.6 | FDA 21 CFR 182.1320 |
| Silicone oil | 17 | -90 | +200 | 0.92 | 4.4 | for low temperatures |
| Halocarbon | 21 | -60 | +175 | 1.89 | 10.6 | for oxygen ¹⁾ and chlorine |
| Methylcyclopentane | 30 | -130 | +60 | 0.74 | 0.7 | for low temperatures |
| High-temperature silicone oil | 32 | -25 | +400 | 1.06 | 47.1 | for high temperatures |
| Caustic soda | 57 | -50 | +95 | 1.24 | 4.1 | |
| Neobee [®] M-20 | 59 | -35 | +260 | 0.92 | 10.0 | FDA 21 CFR 172.856, 21 CFR 174.5 |
| DI water | 64 | +4 | +85 | 1.00 | 0.9 | for ultrapure media |
| Silicone oil | 68 | -75 | +250 | 0.93 | 10.3 | |
| DI water/propanol mixture | 75 | -30 | +60 | 0.92 | 3.6 | for ultrapure media |
| Medicinal white mineral oil | 92 | -15 | +260 | 0.85 | 45.3 | FDA 21 CFR 172.878, 21 CFR 178.3620(a); USP, EP |

Note:

- The stated lower temperature limit (solidification point) is a purely physical characteristic of the system fill fluid. Calculate and evaluate the resulting response time separately.
- The upper temperature limit (boiling/degradation point) for a diaphragm seal system is further restricted by the working pressure and the diaphragm. To determine the upper temperature limit for the individual diaphragm seal system, a calculation is required.

1) For oxygen applications the following values per BAM test (Federal Institute for Materials Research and Testing) apply:

Diaphragm seal variants

Diaphragm seals

Diaphragm seals are mounted to existing fittings or flanges. Usually the fittings consist of T-pieces which are integrated into a pipeline, or of welding sockets which are welded to a pipeline, the process reactor or a tank. This diaphragm seal type offers the advantage that the “contact surface” between pressure medium and diaphragm is relatively large, thus ensuring accurate pressure measurement, especially for very low pressures (< 600 mbar). The fact that they can be easily dismantled, e.g. for cleaning or calibration purposes, is a further advantage.

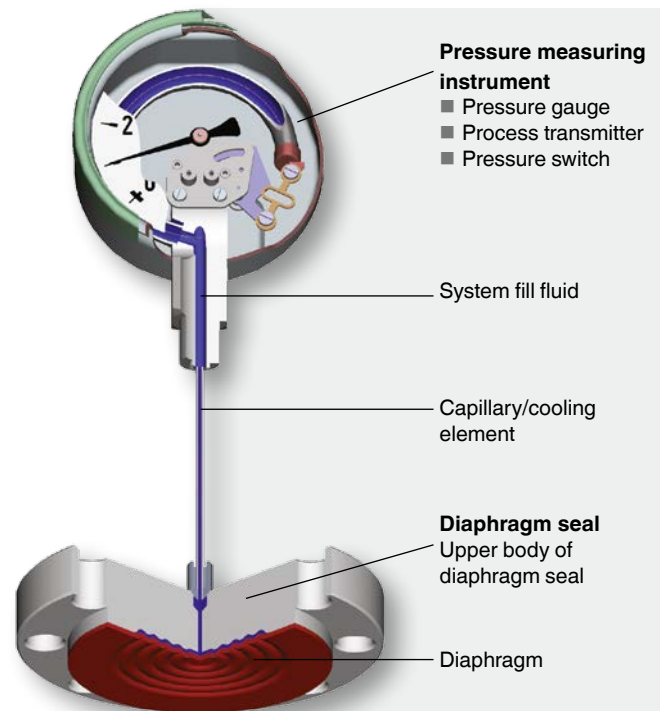

In-line diaphragm seal

The in-line diaphragm seal is perfectly suited for use with flowing media. With the seal being completely integrated into the process line, measurements do not cause any turbulence, corners, dead spaces or other obstructions in the flow direction. The in-line diaphragm seal is installed directly into the pipeline; this makes the designing of special measuring point connections unnecessary.

In comparison with other designs with grooves or non-circular geometry, in-line diaphragm seals with their perfectly circular cylindrical form are self-cleaning. Different nominal widths allow the in-line diaphragm seals to be adapted to any pipeline cross-section.

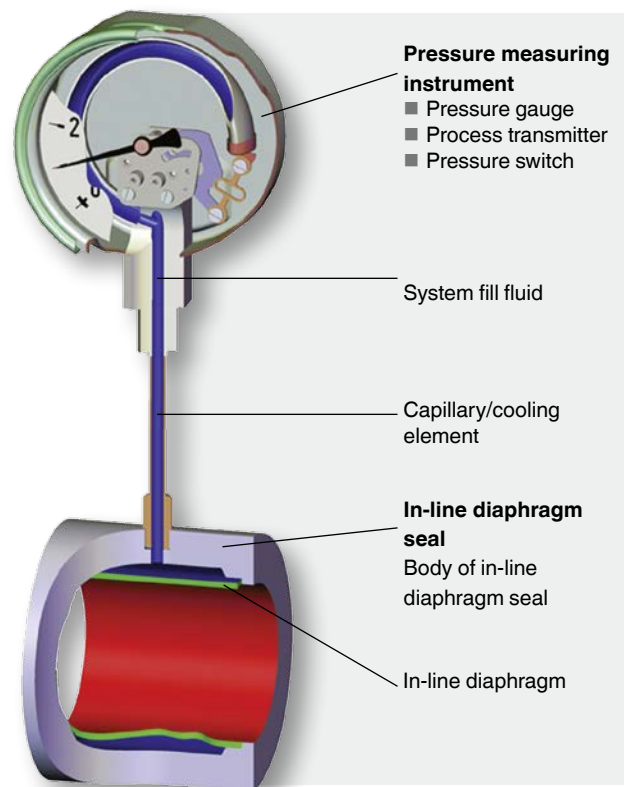

Electronic pressure measuring instruments

WIKA offers a complete range of electronic pressure measuring instruments for the measurement of gauge pressure, absolute pressure, differential pressure, level and flow. We offer solutions for measuring ranges from 0 ... 1 mbar to 0 ... 6,000 bar with accuracies from 0.075 %.

When connected to diaphragm seals these instruments can also be used with both highly-aggressive and high-temperature media. With their 'intrinsically safe' and 'explosion proof enclosure' types of protection the electronic pressure measuring instruments from WIKA are ideally suited for permanent use in hazardous environments (zone 0).

They can measure the pressure of, e.g., gases, mist and dusts. A wide range of configuration options at the instrument or via software enable the instrument to be easily set-up for the particular measuring task, e.g. input of the tank geometry or the density of the medium. Whether standard instrument or customer-specific version - for every application the optimal solution.

DPT-10

Differential pressure transmitter, intrinsically safe or with flame-proof enclosure



Non-linearity (% of span): $\leq 0.075 \dots 0.15$

Measuring range: 0 ... 10 mbar to 0 ... 40 bar

- Special feature:
- Freely scalable measuring ranges
 - Static load 160 bar, optionally 420 bar
 - Case from plastic, aluminium or stainless steel
 - With integrated display and mounting bracket for wall/pipe mounting (optional)

Data sheet: PE 86.21

IPT-10

Process pressure transmitter, intrinsically safe or with flameproof enclosure



Non-linearity (% of span): $\leq 0.075 \dots 0.1$

Measuring range: ■ 0 ... 0.1 to 0 ... 4,000 bar

- -1 ... 0 to -1 ... +60 bar
- 0 ... 0.1 to 0 ... 60 bar abs.

- Special feature:
- Freely scalable measuring ranges
 - Case from plastic, aluminium or stainless steel
 - Flush process connection (optional)
 - With integrated display and mounting bracket for wall/pipe mounting (optional)

Data sheet: PE 86.11

UPT-20

Universal process transmitter, intrinsically safe

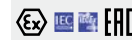

Non-linearity (% of span): ≤ 0.1

Output signal: 4 ... 20 mA, HART®

- Measuring range:
- 0 ... 0.4 to 0 ... 1,000 bar
 - 0 ... 1.6 to 0 ... 40 bar abs.
 - -0.2 ... +0.2 to -1 ... +40 bar

- Special feature:
- Multi-functional display
 - Free scaleable measuring ranges
 - Simple menu navigation
 - Conductive plastic case and stainless steel case made in Hygienic design
 - Large LC display, rotatable
 - Mounting bracket for wall or pipe mounting

Data sheet: PE 86.05

IL-10

Submersible pressure transmitter,
intrinsically safe



Accuracy (\pm % of span): 0.25 or 0.5
 Measuring range: 0 ... 0.1 to 0 ... 25 bar gauge
 Special feature:

- Hastelloy design (optional)
- Highly resistive FEP cable (optional)

 Data sheet: PE 81.23



IS-20, IS-21

Pressure transmitter,
intrinsically safe



Accuracy (% of span): ≤ 0.5
 Measuring range:

- 0 ... 0.1 to 0 ... 6,000 bar gauge
- 0 ... 0.25 to 0 ... 25 bar abs.

 Special feature:

- Further worldwide Ex approvals
- High-pressure version (optional)
- Flush process connection (optional)
- Suitable for SIL 2 per IEC 61508/IEC 61511

 Data sheet: PE 81.50, PE 81.51, PE 81.52 (GL)

IS-3

Pressure transmitter,
Ex ia, Ex nA, Ex tc



Accuracy (% of span): ≤ 0.5
 Measuring range:

- 0 ... 0.1 to 0 ... 6,000 bar
- 0 ... 0.25 to 0 ... 25 bar abs.
- -1 ... 0 to -1 ... +24 bar

 Special feature:

- Further worldwide Ex approvals
- High-pressure version (optional)
- Flush process connection (optional)
- Suitable for SIL 2 per IEC 61508/IEC 61511

 Data sheet: PE 81.58

E-10

Pressure transmitter,
with flameproof enclosure



Accuracy (% of span): ≤ 0.5
 Measuring range:

- 0 ... 0.4 to 0 ... 1,000 bar gauge
- 0 ... 0.4 to 0 ... 16 bar abs.

 Special feature:

- Low-power version
- For sour gas applications (NACE)
- Flush process connection (optional)

 Data sheet: PE 81.27

Mechatronic pressure measuring instruments

PGT23

Bourdon tube, stainless steel version



Nominal size: 100, 160 mm
 Scale range: 0 ... 0.6 to 0 ... 1,600 bar
 Accuracy class: 1.0
 Ingress protection: IP 54, filled IP 65
 Data sheet: PV 12.04

PGS23

Bourdon tube, stainless steel version



Nominal size: 100, 160 mm
 Scale range: 0 ... 0.6 to 0 ... 1,600 bar
 Accuracy class: 1.0
 Ingress protection: IP 65
 Data sheet: PV 22.02

DPGS43

Differential pressure, stainless steel version



Nominal size: 100, 160 mm
 Scale range: 0 ... 16 mbar to 0 ... 25 bar
 Accuracy class: 1.6
 Ingress protection: IP 54, filled IP 65
 Data sheet: PV 27.05

PGT43

Diaphragm, stainless steel version



Nominal size: 100, 160 mm
 Scale range: 0 ... 16 mbar to 0 ... 25 bar
 Accuracy class: 1.6
 Ingress protection: IP 54, filled IP 65
 Data sheet: PV 14.03

PGS43

Diaphragm, stainless steel version



Nominal size: 100, 160 mm
 Scale range: 0 ... 25 mbar to 0 ... 25 bar
 Accuracy class: 1.6
 Ingress protection: IP 54, filled IP 65
 Data sheet: PV 24.03

DPGT43

Differential pressure, stainless steel version



Nominal size: 100, 160 mm
 Scale range: 0 ... 16 mbar to 0 ... 25 bar
 Accuracy class: 1.6
 Ingress protection: IP 54, filled IP 65
 Data sheet: PV 17.05

Mechanical pressure switches

Mechanical pressure switches open or close a circuit, depending on whether the pressure is rising or dropping. Due to the use of high-quality micro switches, the mechanical pressure switches are notable for their high precision and long-term stability. Furthermore the direct switching of electrical loads up to AC 250 V / 20 A is enabled, while simultaneously ensuring a high switch point reproducibility.

Many mechanical pressure switches come with a SIL certificate and are thus particularly suited for safety-critical applications. In addition, with their 'intrinsically safe' and 'flameproof enclosure' types of protection the pressure switches are ideally suited for permanent use in hazardous environments.

for gauge pressure

MW, MA

Diaphragm element



Setting range: 0 ... 16 mbar to 30 ... 600 bar
 Ignition protection type: Ex-ia or Ex-d
 Switch: 1 or 2 x SPDT or 1 x DPDT
 Switching power: AC 250 V / 20 A
 DC 24 V / 2 A
 Data sheet: PV 31.10, PV 31.11

BWX, BA

Bourdon tube



Setting range: 0 ... 2.5 to 0 ... 1,000 bar
 Ignition protection type: Ex-ia or Ex-d
 Switch: 1 or 2 x SPDT or 1 x DPDT
 Switching power: AC 250 V / 20 A
 DC 24 V / 2 A
 Data sheet: PV 32.20, PV 32.22

PCS, PCA

Compact pressure switches



Setting range: -0.2 ... 1.2 to 100 ... 600 bar
 Ignition protection type: Ex-ia or Ex-d
 Switch: 1 x SPDT or DPDT
 Switching power: AC 250 V / 15 A
 DC 24 V / 2 A
 Data sheet: PV 33.30, PV 33.31

for differential pressure

DW, DA

Differential pressure switches



Setting range: 0 ... 16 mbar to 0 ... 40 bar
 Ignition protection type: Ex-ia or Ex-d
 Static pressure: 10, 40, 100 or 160 bar
 Switch: 1 or 2 x SPDT or 1 x DPDT
 Switching power: AC 250 V / 20 A
 DC 24 V / 2 A
 Data sheet: PV 35.42, PV 35.43

Mechanical pressure measuring instruments



with Bourdon tube

232.50, 233.50

Stainless steel version



Ex EAC GL

Nominal size: 63, 100, 160 mm
 Scale range:
 ■ NS 63: 0 ... 1.0 to 0 ... 1,000 bar
 ■ NS 100: 0 ... 0.6 to 0 ... 1,000 bar
 ■ NS 160: 0 ... 0.6 to 0 ... 1,600 bar
 Accuracy class: 1.0/1.6 (NS 63)
 Ingress protection: IP 65
 Data sheet: PM 02.02

232.30, 233.30

Safety version, stainless steel



Ex EAC S

Nominal size: 63, 100, 160 mm
 Scale range:
 ■ NS 63: 0 ... 1.0 to 0 ... 1,000 bar
 ■ NS 100: 0 ... 0.6 to 0 ... 1,000 bar
 ■ NS 160: 0 ... 0.6 to 0 ... 1,600 bar
 Accuracy class: 1.0 (NS 100, 160), 1.6 (NS 63)
 Ingress protection: IP 65
 Data sheet: PM 02.04

232.34, 233.34

Process Gauge, safety version



EAC

Nominal size: 4 1/2"
 Scale range: 0 ... 0.6 bar to 0 ... 1,000 bar
 (0 ... 10 psi to 0 ... 15,000 psi)
 Accuracy class: Grade 2A per ASME B 40.1
 (corresponds to indication accuracy 0.5%)
 Ingress protection: IP 54 (with liquid filling IP 65)
 Data sheet: PM 02.10

with diaphragm or capsule element

432.50, 433.50

Stainless steel, for low pressures, for critical media



Nominal size: 100, 160 mm
 Scale range: 0 ... 16 mbar to 0 ... 25 bar
 Accuracy class: 1.6
 Ingress protection: IP 54, filled IP 65
 Overpressure: 5 x full scale value, max. 40 bar, optionally 10 x full scale value
 Data sheet: PM 04.03

632.50

Stainless steel version, for very low pressures



Nominal size: 63, 100, 160 mm
 Scale range: ■ NS 63: 0 ... 40 to 0 ... 600 mbar
 ■ NS 100: 0 ... 16 to 0 ... 600 mbar
 ■ NS 160: 0 ... 2.5 to 0 ... 600 mbar
 Accuracy class: 1.6
 Ingress protection: IP 65
 Data sheet: PM 06.03

532.5x

Stainless steel version, for absolute pressure



Nominal size: 100, 160 mm
 Scale range: 0 ... 25 mbar to 0 ... 25 bar abs.high overpressure safety
 Accuracy class: 0.6 / 1.0 / 1.6 / 2.5
 Ingress protection: IP 54, filled IP 65
 Data sheet: PM 05.02

for differential pressure

732.14

Stainless steel version, high overpressure safety up to max. 400 bar



Nominal size: 100, 160 mm
 Scale range: ■ 0 ... 60 to 0 ... 250 mbar (measuring cell DN 140)
 ■ 0 ... 0.4 to 0 ... 40 bar (measuring cell DN 80)
 Accuracy class: 1.6
 Ingress protection: IP 54
 Data sheet: PM 07.13

732.51

Stainless steel version, all-metal media chamber



Nominal size: 100, 160 mm
 Scale range: 0 ... 16 mbar to 0 ... 25 bar
 Accuracy class: 1.6
 Ingress protection: IP 54
 Data sheet: PM 07.05



Accessories for pressure gauges

910.10, 910.11, 910.81

Stopcocks and shut-off valves



Application: For pressure gauge isolation
Data sheet: AC 09.01, AC 09.02, AC 09.18

910.80

Monoflange



Application: For pressure gauge isolation
Data sheet: AC 09.17

910.25

Pressure compensating valve for differential pressure gauges

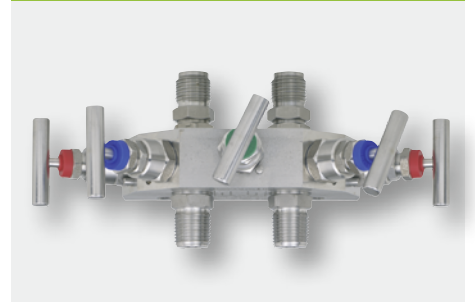

Application: For isolating, pressure compensating as well as purging and venting differential pressure gauges
Data sheet: AC 09.11

910.12, 910.13

Snubbers and overpressure protectors

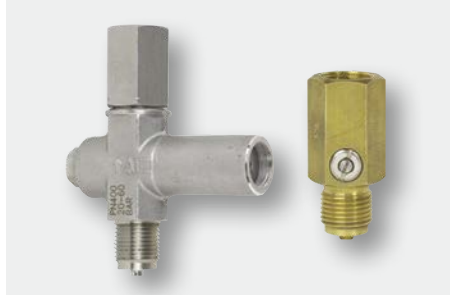

Application: For the protection of pressure gauges from pressure surges and pulsations or overpressures
Data sheet: AC 09.03, AC 09.04

910.15

Syphon



Application: For the protection of pressure gauges from excessive pulsation and heat
Data sheet: AC 09.06

Diaphragm seals

The combination of pressure measuring instruments with diaphragm seals has multiplied the application areas of the measuring instruments considerably. At WIKA there are currently more than 15,000 different diaphragm seal variants available. This enables process engineers to measure pressure with instruments that are individual and custom-made for the application, and so are ideally tailored to their chemical processes.



Possibilities for combination and assembly of pressure measuring instruments and diaphragm seals

Assembly of the diaphragm seal and measuring instrument may be made via a direct connection or a flexible capillary. The rigid assembly is made by a direct threaded connection

or by welding the measuring instruments to the diaphragm seal or via an adapter. For high temperatures a cooling element can be fitted between seal and instrument.

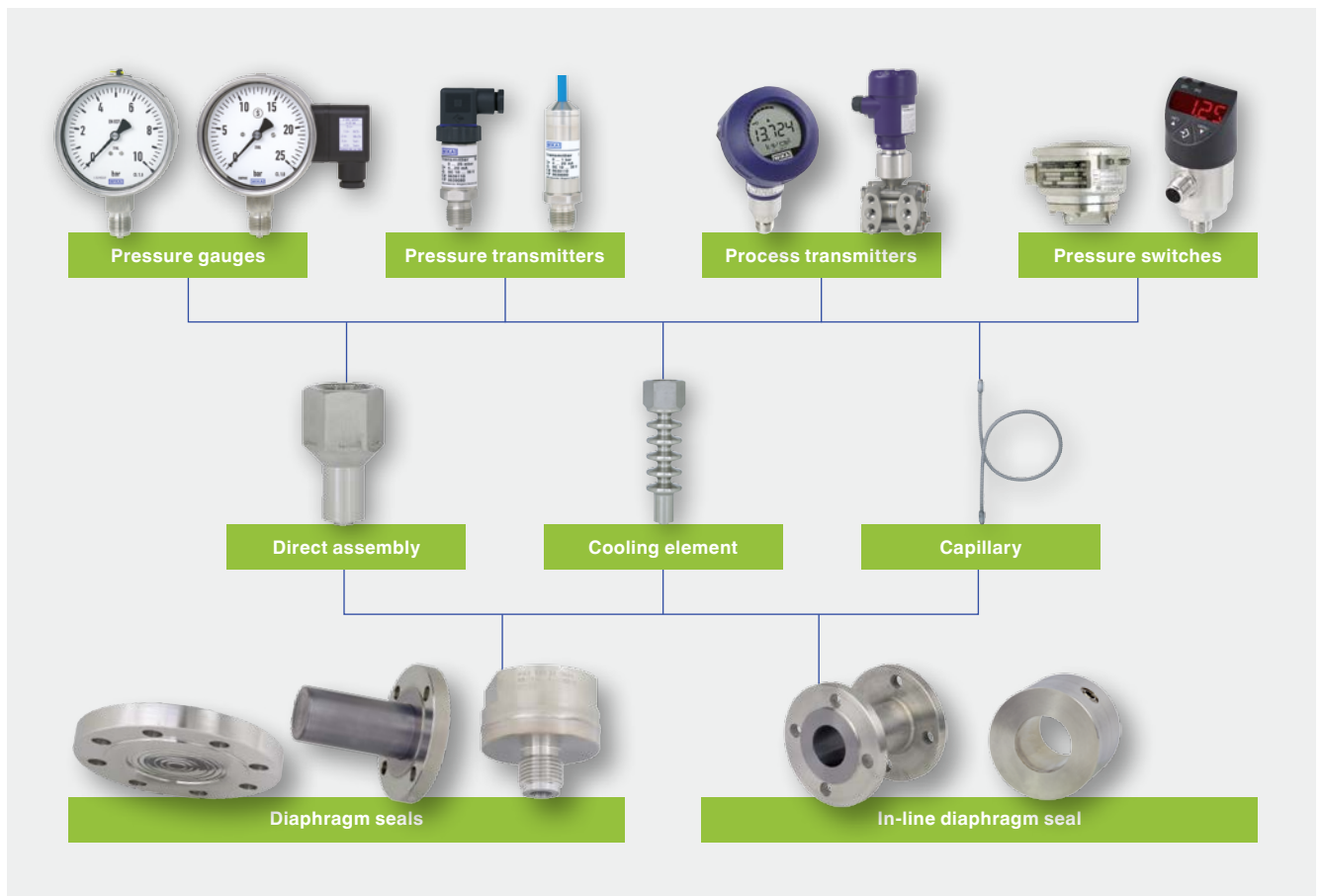

Diaphragm seals

with flange connection

990.27

Flush diaphragm



Application: Process and petrochemical industries with high measuring requirements
 PN max: 10 ... 250 (400) bar (class 150 ... 2,500)
 Data sheet: DS 99.27

990.28

Cell-type



Application: Process and petrochemical industries with high measuring requirements
 PN max: 10 ... 100 (400) bar (class 150 ... 2,500)
 Data sheet: DS 99.28

910.27

Flushing ring for flanges per EN 1092-1 and ASME B 16.5



Application: For flange-type and cell-type diaphragm seals, models 990.27 and 990.28, to avoid any deposits or clogging in the process connection fitting
 PN max: PN 600 bar
 Class 150 ... 600
 Data sheet: AC 91.05

990.26

Internal diaphragm



Application: Process industry; for small flange connections (\leq DN 25/1")
 PN: 10 ... 40 bar (class 150 ... 300)
 Data sheet: DS 99.26

990.41

Large working volume, threaded design



Application: To combine with capsule or diaphragm pressure gauges and transmitters for low pressures
 PN max: 10 ... 40 bar (class 150 ... 300)
 Data sheet: DS 99.32

990.29

Flange-type with extended diaphragm



Application: Process and petrochemical industries, particularly for thick or insulated tank walls
 PN max: 10 ... 100 (400) bar (class 150 ... 2,500)
 Data sheet: DS 99.29

for in-line measurement

981.10

In-line diaphragm seal, cell-type



Application: For direct, permanent installation in pipelines; for flowing media; for measuring points free of dead space
 PN max: 400 bar
 Data sheet: DS 98.28

981.27

In-line diaphragm seal, flange-type



Application: For direct, permanent installation in pipelines; for flowing media; for measuring points free of dead space
 PN max: 16 or 40 bar
 Data sheet: DS 98.27

990.15

Diaphragm seal for block flange or saddle flange



Accessories

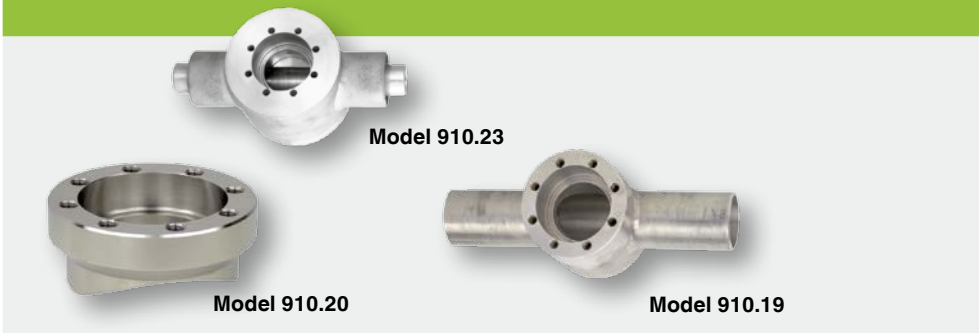

Application: Chemical process technology; system for the production of output terminals and for the integration of the measuring instruments into the product pipeline
 PN max [bar]: 100/250
 Wetted parts: Stainless steel 316L, for special materials see table on page 7
 Sealing: FPM (Viton®)
 Diaphragm arrangement: Flush
 Model: ■ Diaphragm seal 990.15
 ■ Block flange for single pipes 910.19
 ■ Block flange for double-jacket pipes 910.23
 ■ Saddle flange 910.20
 Data sheet: ■ DS 99.35
 ■ AC 91.01

Diaphragm seals

with threaded connection

990.10

Threaded design



Application: General applications in the process industry
PN max: 25, 100 or 250 bar
Data sheet: DS 99.01

990.36

Small diaphragm seal with flush diaphragm



Application: Particularly for highly viscous and crystallising media
PN max: 600 bar
Data sheet: DS 99.03

990.34

Welded design



Application: Machine-building, plant-construction and process-industry applications with high requirements
PN max: 160, 400, 600 or 1,000 bar
Data sheet: DS 99.04



Electrical temperature measuring instruments

For electrical temperature measurement, WIKA designs and manufactures resistance thermometers, thermocouples and temperature transmitters. Particularly resistance thermometers are suited to the process conditions and to the measurement accuracy requirements of applications in both the chemical and the pharmaceutical and biotechnology industries.

Transmitters convert the temperature-dependent change in resistance of resistance thermometers or the temperature-dependent voltage change in a thermocouple into a proportional standard signal.

The most commonly used standard signal is the analogue 4 ... 20 mA signal, though digital signals (fieldbus) are gaining more and more importance.

By using intelligent circuit concepts with analogue 4 ... 20 mA signals, any sensor errors that occur are signalled and simultaneously transmitted with the measured value over a two-wire line (current loop).

The conversion and transmission of the standard signals (analogue or digital) is made over long distances and completely fail-safe. A temperature transmitter can either be mounted directly at the measuring point in the connection head or on a DIN rail in a cabinet.

All resistance thermometers and transmitters listed can also be used in hazardous areas. In addition to this they are distinguished by a wide permissible ambient temperature range of -40 ... +85 °C with a maximum humidity of 100 %.

Our extensive range is completed by high-quality, functional temperature transmitters. Instruments with 4 ... 20 mA output signal as well as HART®, PROFIBUS® PA and FOUNDATION™ Fieldbus interface are available.

Possibilities for combination of electrical thermometers with transmitters



Resistance thermometers

Resistance thermometers

Resistance thermometers are equipped with platinum sensor elements which change their electrical resistance as a function of temperature. In our range of products you will find resistance thermometers with connected cable as well as versions with connection head. A temperature transmitter can be installed directly in the connection head.

Resistance thermometers are suitable for applications between -200 ... +600 °C (dependent on instrument model, sensor element and materials coming into contact with the medium).

Accuracy classes AA, A and B apply to all resistance thermometers. They are available with a sensor limiting error to DIN EN 60751.

TR10-A

Measuring insert



Sensor element: 1 x Pt100, 2 x Pt100
 Measuring range: -200 ... +600 °C
 Connection method: 2-, 3- and 4-wire
 Data sheet: TE 60.01

TR10-B

For additional thermowell



Sensor element: 1 x Pt100, 2 x Pt100
 Measuring range: -200 ... +600 °C
 Connection method: 2-, 3- and 4-wire
 Data sheet: TE 60.02

TR10-C

To screw in, with fabricated thermowell



Sensor element: 1 x Pt100, 2 x Pt100
 Measuring range: -200 ... +600 °C
 Connection method: 2-, 3- and 4-wire
 Process connection: Mounting thread
 Data sheet: TE 60.03

TR10-F

Flanged resistance thermometer, with fabricated thermowell



Sensor element: 1 x Pt100, 2 x Pt100
 Measuring range: -200 ... +600 °C
 Connection method: 2-, 3- and 4-wire
 Process connection: Flange
 Data sheet: TE 60.06

TR10-L

Flameproof enclosure, for additional thermowell



Sensor element: 1 x Pt100, 2 x Pt100
 Measuring range: -200 ... +600 °C
 Connection method: 2-, 3- and 4-wire
 Data sheet: TE 60.12

TR12-B

Process resistance thermometer, for additional thermowell



Sensor element: 1 x Pt100, 2 x Pt100
 Measuring range: -200 ... +600 °C
 Connection method: 2-, 3- and 4-wire
 Option: Ex i, Ex d
 Data sheet: TE 60.17

TR33

Miniature design



Sensor element: 1 x Pt100, 1 x Pt1000
 Measuring range: -50 ... +250 °C
 Output: Pt100, Pt1000, 4 ... 20 mA
 Data sheet: TE 60.33

TR34

Miniature design, explosion-protected



Sensor element: 1 x Pt100, 1 x Pt1000
 Measuring range: -50 ... +250 °C
 Connection method: Pt100, Pt1000, 4 ... 20 mA
 Data sheet: TE 60.34

TR40

Cable resistance thermometer

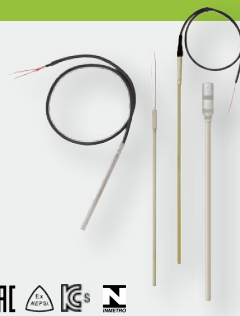

Sensor element: 1 x Pt100, 2 x Pt100
 Measuring range: -200 ... +600 °C
 Connection method: 2-, 3- and 4-wire
 Cable: PVC, silicone, PTFE
 Data sheet: TE 60.40

Customer-specific solutions

TR95

Multipoint temperature measurement



Chemical reactions are very strongly affected by the temperature. This means that if the temperature within a reactor varies widely, one can also assume that the chemical reaction will not occur homogeneously.

The measurement of the temperature distribution within a plant element can be realised cost-effectively using WIKA multi-point assemblies. Multi-point assemblies are always designed and built to the individual requirements of our customers. They can contain up to 50 individual temperature measuring points, whose measurement signals can be read directly or by means of transmitters.

Thermocouples

Thermocouples generate a voltage directly dependent on temperature. They are particularly suitable for high temperatures up to 1,600 °C and at very high oscillating stresses. Accuracy classes 1 and 2 apply to all thermocouples.

They are available with a sensor limiting error to DIN EN 60584. In our range of products you will find all market-standard instrument versions. If required, a temperature transmitter can be installed in the connection head.

TC10-A

Measuring insert



Sensor element: Type K, J, E, N or T
 Measuring range: -200 ... +1,200 °C
 Measuring point: Ungrounded or grounded
 Data sheet: TE 65.01

TC10-B

For additional thermowell



Sensor element: Type K, J, E, N or T
 Measuring range: -200 ... +1,200 °C
 Measuring point: Ungrounded or grounded
 Data sheet: TE 65.02

TC10-C

To screw in, with fabricated thermowell



Sensor element: Type K, J, E, N or T
 Measuring range: -200 ... +600 °C
 Measuring point: Ungrounded or grounded
 Process connection: Mounting thread
 Data sheet: TE 65.03

TC10-F

Flanged thermocouple, with fabricated thermowell



Sensor element: Type K, J, E, N or T
 Measuring range: -200 ... +600 °C
 Measuring point: Ungrounded or grounded
 Process connection: Flange
 Data sheet: TE 65.06

TC10-L

Flameproof enclosure, for additional thermowell



Sensor element: Type K, J, E, N or T
 Measuring range: -200 ... +1,200 °C
 Measuring point: Ungrounded or grounded
 Data sheet: TE 65.12

TC12-B

Process thermocouple, for additional thermowell



Sensor element: Type K, J, E or N
 Measuring range: -200 ... +1,200 °C
 Measuring point: Ungrounded or grounded
 Option: Ex i, Ex d
 Data sheet: TE 65.17

TC40

Cable thermocouple



Sensor element: Type K, J, E, N or T
 Measuring range: -200 ... +1,260 °C
 Measuring point: Ungrounded or grounded
 Cable: PVC, silicone, PTFE, glass fibre
 Data sheet: TE 65.40

TC80

Thermocouple for high-temperature measurements



Sensor element: Type S, R, B, K, N or J
 Measuring range: -200 ... +1,600 °C
 Measuring point: Ungrounded
 Process connection: Stop flange, threaded bushing
 Data sheet: TE 65.80

Customer-specific solutions

TC59

TubeSkin thermocouple



Sensor element: Type K or N
 Measuring range: 0 ... +1,200 °C
 Measuring point: Ungrounded or grounded
 Process connection: Surface mounting
 Data sheet: TE 65.59

TC90

High-pressure thermocouple



With our new generation of TC90 high-pressure thermocouples, reliable temperature measurement in, for example, plastics production and processing applications is possible. Each TC90 high-pressure thermocouple is individually manufactured and tested to customer specification. These instruments are manufactured using special manufacturing processes and, in order to ensure their quality, special test arrangements and material tests are applied. This measuring assembly is sealed by means of metal-to-metal sealing, high-pressure threaded connectors or sealing lenses, which have both proven successful over many years.

Data sheet: TE 65.90

TC95

Multipoint thermocouple



Chemical reactions are very strongly affected by the temperature. This means that if the temperature within a reactor varies widely, one can also assume that the chemical reaction will not occur homogeneously. The measurement of the temperature distribution within a plant element can be realised cost-effectively using WIKAI multi-point assemblies. Multi-point assemblies are always designed and built to the individual requirements of our customers. They can contain up to 50 individual temperature measuring points, whose measurement signals can be read directly or by means of transmitters.

Data sheet: TE 70.01

Application-oriented solutions



Multipoint TC96
(Gayesco Flex-R)



Multipoints

- Free-hanging and spring-loaded multipoint thermocouples and multipoint thermocouples with fabricated thermowell for use in catalytic reactors, reformers and heat exchangers.
- Borehole thermocouples for temperature monitoring in various zones in oil and gas wells. These mineral-insulated, metal-sheathed thermocouples can exceed 3,000 metres (10,000 ft) in length.
- Resistance thermometers with multipoint sensors, for applications requiring high precision for monitoring vessels and for level control.

Proper installation by field service

A correct installation is essential for industrial temperature measurement. WIKA/Gayesco services also provide installation support up to and including full turnkey installations for those clients who want to be sure that multipoints or tubeskin thermocouples are installed properly.

Our field service team has created installation animations to help those clients who want to install the product themselves. On request, installation support (supervising) is provided for these activities.



Various multipoint versions, Tx95 and TC96



Trained specialist installing a tubeskin thermometer

Temperature transmitters and field indicators

T32

HART® transmitter



Input: Resistance thermometers, thermocouples, potentiometers
 Accuracy: < 0.1 %
 Output: 4 ... 20 mA, HART® protocol
 Special feature: TÜV certified SIL version (full assessment)
 Data sheet: TE 32.04

T53

FOUNDATION™ Fieldbus und PROFIBUS® PA transmitter



Input: Resistance thermometers, thermocouples, potentiometers
 Accuracy: < 0.1 %
 Special feature: PC configurable
 Data sheet: TE 53.01

T12

Universally programmable digital transmitter



Input: Resistance thermometers, thermocouples
 Accuracy: < 0.2 %
 Output: 4 ... 20 mA
 Special feature: PC configurable
 Data sheet: TE 12.03

DIH50, DIH52

Field indicator for current loops with HART® communication



Dimensions: 150 x 127 x 127 mm
 Case: Aluminium, stainless steel
 Special feature:

- Adjustment of indication range and unit via HART® communication
- Model DIH52 additionally suitable for multidrop operation and with local master function

 Approval:

- Intrinsically safe per ATEX
- Flameproof enclosure

 Data sheet: AC 80.10

TIF50, TIF52

HART® field temperature transmitter



Input: Resistance thermometers, thermocouples, potentiometers
 Accuracy: < 0.1 %
 Output: 4 ... 20 mA, HART® protocol
 Special feature: PC configurable
 Data sheet: TE 62.01

Mechatronic temperature measuring instruments

55 with 8xx

Bimetal thermometer, stainless steel version



Nominal size: 63, 100, 160 mm
 Scale range: -70 ... +30 to 0 ... +600 °C
 Wetted parts: Stainless steel
 Option: Liquid damping to max. 250 °C (case and sensor)
 Data sheet: TV 25.01



54

Twin-Temp bimetal thermometer with Pt100



Nominal size: 63, 80, 100, 160 mm
 Scale range: 0 ... +50 to 0 ... +250 °C
 Wetted parts: Stainless steel
 Option: Liquid damping to max. 250 °C (case and sensor)
 Data sheet: TV 15.01

73 with 8xx

Gas-actuated thermometer, stainless steel version



Nominal size: 100, 160, 144 x 144 mm
 Scale range: -200 ... +100 to 0 ... +700 °C
 Wetted parts: Stainless steel
 Option: ■ Capillary ■ Liquid damping (case)
 Data sheet: TV 27.01

TGT73

intelliTHERM® gas-actuated thermometer



Nominal size: 100, 160 mm
 Scale range: -200 ... +100 to 0 ... +700 °C
 Wetted parts: Stainless steel
 Option: ■ Capillary ■ Liquid damping (case)
 Data sheet: TV 17.10

Mechanical temperature switches

Mechanical temperature switches open or close a circuit, depending on whether the temperature is rising or dropping. Due to the use of high-quality micro switches, the mechanical temperature switches from WIKA are notable for their high precision and long-term stability. Furthermore the direct switching of electrical loads up to AC 250 V / 20 A is enabled, while simultaneously ensuring a high switch point reproducibility.

All switches offer IP 66 ingress protection as standard.

The instruments are available with a direct connection or a capillary with a length of up to 10 metres.

Particularly for use in safety-critical applications some mechanical temperature switches come with a SIL certificate. In addition, with their 'intrinsically safe' and 'flameproof enclosure' types of protection the switches are ideally suited for permanent use in hazardous environments. On customer request the use of high-quality and corrosion-resistant wetted materials is confirmed by a 3.1 certificate per EN 10204.

TWG, TAG

Heavy-duty version



Ex EAC SIL

Setting range: -30 ... +70 to 0 ... 600 °C
 Ignition protection type: Ex-ia or Ex-d
 Switch: 1 or 2 SPDT or 1 x DPDT
 Switching power: AC 250 V / 20 A
 DC 24 V / 2 A
 Data sheet: TV 31.60, TV 31.61

TCS, TCA

Compact temperature switches



Ex EAC SIL

Setting range: -30 ... +10 to +160 ... +250 °C
 Ignition protection type: Ex-ia or Ex-d
 Switch: 1 x SPDT or 1 x DPDT
 Switching power: AC 250 V / 15 A
 DC 24 V / 2 A
 Data sheet: TV 31.64, TV 31.65 (Ex)

TXS, TXA

Mini temperature switches



Ex EAC

Setting range: -15 ... +20 to +180 ... +250 °C
 Ignition protection type: Ex-ia or Ex-d
 Switch: 1 x SPDT
 Switching power: AC 220 V / 5 A
 DC 24 V / 5 A
 Data sheet: TV 31.70, TV 31.72 (Ex)

Mechanical temperature measuring instruments

Gas-actuated thermometers

The measuring system consists of a stem, capillary and Bourdon tube in the case. The entire measuring system is filled with an inert gas under pressure. Any change in temperature at the stem causes a change in internal pressure in the entire measuring system. The pressure thus deforms the Bourdon tube and the deflection is transferred to the pointer.

By using a long capillary line, remote sensing of the temperature over distances up to 100 m becomes possible.

Variations in the ambient temperature acting on the case are compensated for by a bimetal element mounted between the movement and the Bourdon tube.



R73, S73, A73

Axial and radial,
adjustable stem and dial



Nominal size: 100, 160 mm
Scale range: -200 ... +100 to 0 ... +700 °C
Wetted parts: Stainless steel
Option: ■ Liquid damping (case)
 ■ Contact bulb
Data sheet: TM 73.01

Bimetal thermometer

A strip, made from two securely laminated rolled sheets, with metals having different coefficients of expansion (bimetal), will bend on any temperature change. If one end of the bimetal measuring system is fixed securely, the other will rotate the pointer shaft and thus also the pointer.



53

Industrial series, axial, adjustable stem and dial



Nominal size: 3", 5"
 Scale range: -70 ... +70 to 0 ... +600 °C
 Wetted parts: Stainless steel
 Option: Liquid damping to max. 250 °C

Data sheet: TM 53.01

54

Industrial series, axial and radial, adjustable stem and dial



Nominal size: 63, 80, 100, 160 mm
 Scale range: -70 ... +70 to 0 ... +600 °C
 Wetted parts: Stainless steel
 Option: Liquid damping to max. 250 °C (case and sensor)

Data sheet: TM 54.01

55

Stainless steel version, axial and radial, adjustable stem and dial



Nominal size: 63, 100, 160 mm
 Scale range: -70 ... +70 °C to 0 ... +600 °C
 Wetted parts: Stainless steel
 Option: Liquid damping to max. 250 °C (case and sensor)

Data sheet: TM 55.01

Thermowells

Whether in aggressive or abrasive process media, whether in high- or low-temperature ranges: For electrical or mechanical thermometers, to prevent direct exposure of their temperature sensors to the medium, thermowells that suit each application are available.

Thermowells can be machined from solid barstock or assembled from tube sections and can either be screw-, weld- or flange-fitted. They are offered in standard and special materials such as stainless steel 1.4571, 316L, Hastelloy® or titanium. Each version, depending on its construction type and its mounting to the process, has certain advantages and drawbacks with respect to its load limits and the special materials that can be used.

In order to manufacture thermowells for flange mounting at low

cost from special materials, the designs used differ from standard thermowells in accordance with DIN 43772. Thus, only the wetted parts of the thermowell are manufactured from special materials, whereas the non-wetted flange is made of stainless steel and is welded to the special material.

This design is used both for fabricated and solid-machined thermowells. With tantalum as special material a removable jacket is used, which is slid over the supporting thermowell from stainless steel.

Possibilities for combination with thermowells

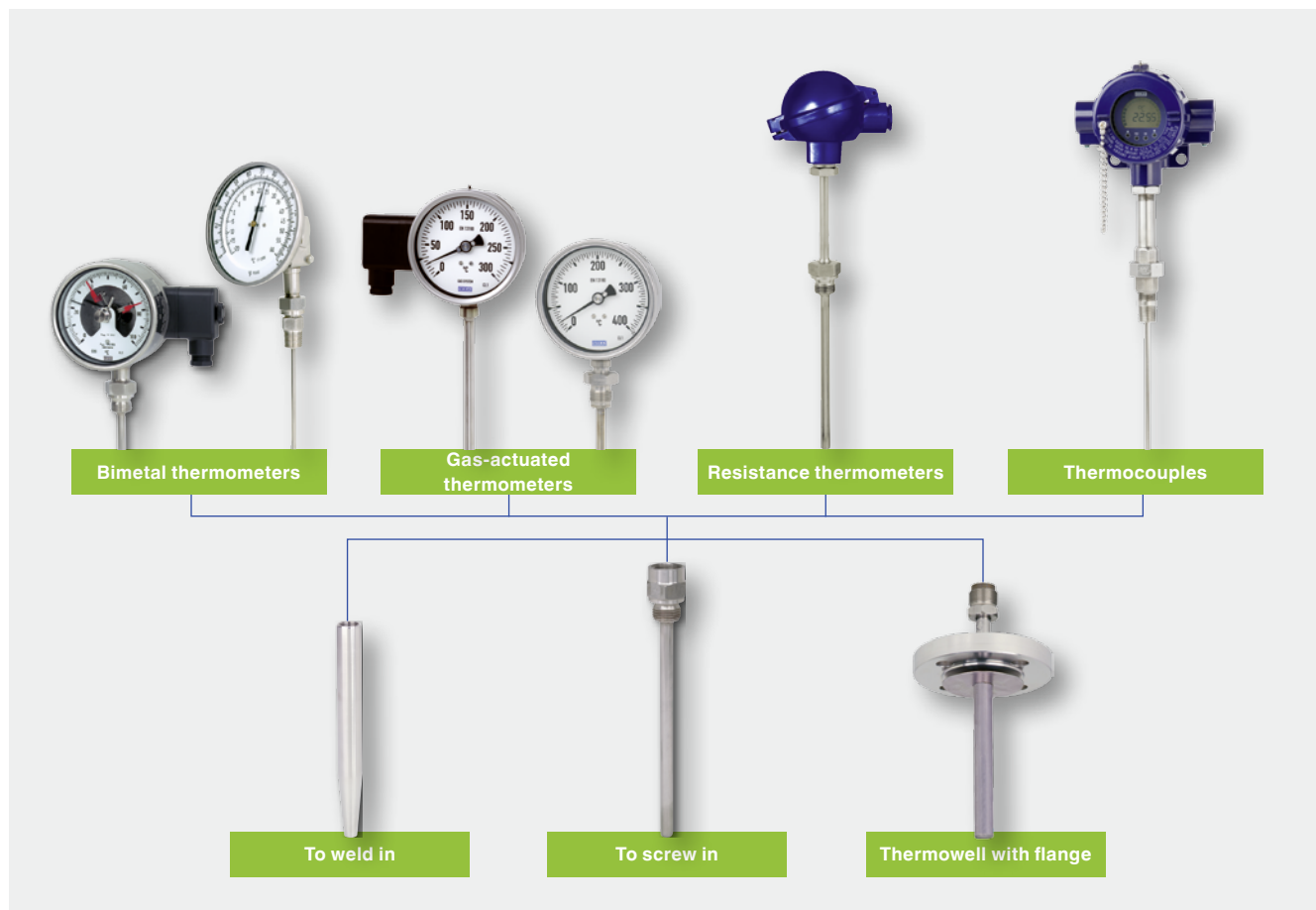

TW10

Solid-machined with flange



Thermowell form: Tapered, straight or stepped
 Nominal width: ASME 1 ... 4 inch
 (DIN/EN DN 25 ... DN 100)
 Pressure rating: ASME to 2,500 lbs (DIN/EN to PN 100)
 Data sheet: TW 95.10, TW 95.11, TW 95.12

TW15

Solid-machined to screw in



Thermowell form: Tapered, straight or stepped
 Head version: Hexagon, round with hexagon, or round
 with spanner flats
 Process connection: 1/2, 3/4 or 1 NPT
 Data sheet: TW 95.15

TW40

Fabricated with flange (DIN 43772 form 2F, 3F)



Thermowell form: Form 2F or 3F
 Nominal width: DIN/EN DN 25 ... DN 50
 (ASME 1 ... 2 inch)
 Pressure rating: DIN/EN to PN 100 (ASME to 1.500 lbs)
 Data sheet: TW 95.40

Coated thermowells for special applications

Special metallic plating can be applied to the surface of a thermowell so it can be used in a process where there is a high risk of abrasion, due to a high flow of suspended solids.

Polymer coatings, on the other hand, are used for highly corrosive processes in which, for example, sulphuric acid is involved.



Thermowells

Welded joints

Internationally, the most common welded joint between flanges and thermowells is the full penetration weld of the flange (full penetration welding, FPW). As well as fulfilling the highest requirements of stability this welding method also meets all requirements of the American flange standard ASME B16.5 for the use of blind flanges.

The WIKA thermowell centre manufactures thermowells to the widest range of welding procedure tests in accordance with ASME Sec. IX for full and partial penetration. The welding procedure tests encompass component dimensions from 5 mm and include all common flange widths. Furthermore, for all common welded joints on fabricated or solid-machined standard thermowells, welding procedure tests are available according to AD2000, HP2/1 (DIN EN ISO 15614/1).

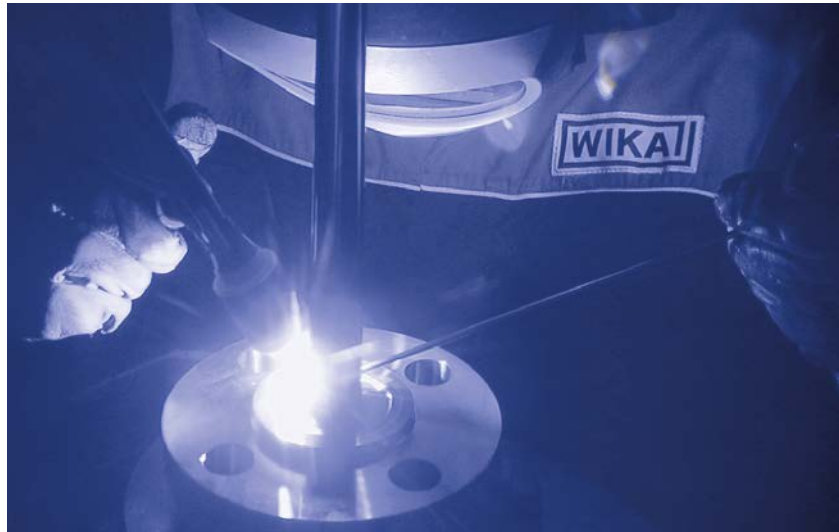

Welding options

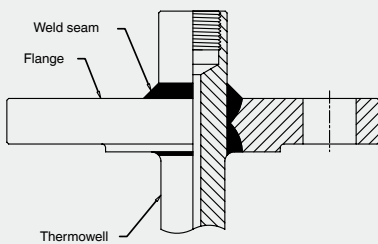

Full penetration weld design

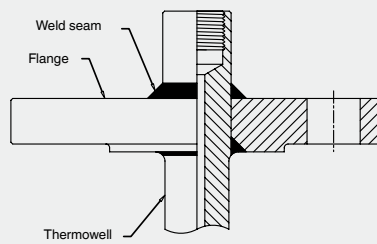

Fillet weld, double-sided

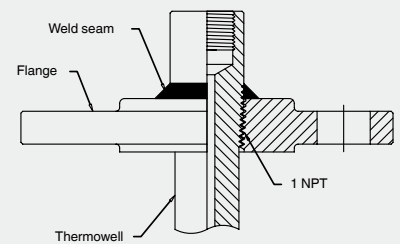

Screwed and welded design

Increased safety

Calculations for establishing the stability of thermowells make it possible to minimise or eliminate the possibility of damage to the thermowells even before the plants where they are used are commissioned. The calculations can be made in accordance with ASME PTC 19.3 / TW-2010 or Dittrich/ Klotter. The following process parameters are required to complete the calculations:

- Flow rate in m/s
- Medium density in kg/m^3
- Temperature in $^{\circ}\text{C}$
- Pressure in bar

Independently of the thermowells' method of manufacture, the results of the thermowell strength calculation are always divided into two parts: Firstly, the dynamic view on vibration failures through operation at resonance and secondly, the static load through external pressure and bending.

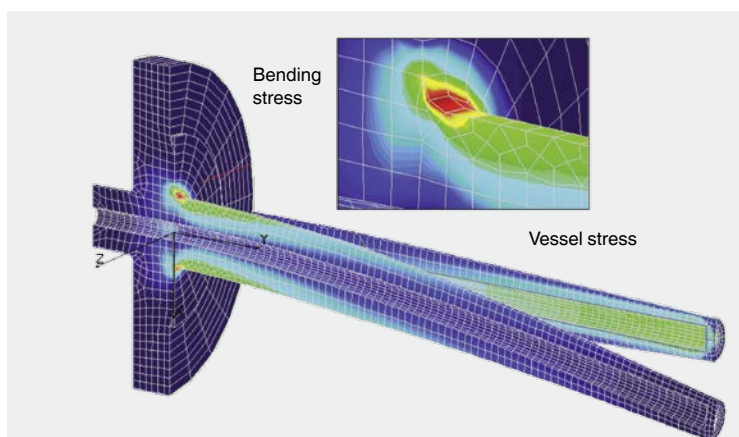

In case of a calculation with negative results, the only constructive solution so far was to shorten the thermowell stem or to increase the root and tip diameter, accepting a longer response time of the thermometer. As alternatives, support collars or thermowells in ScrutonWell® design can be used.

Support collar

For the stabilisation of the stem in the flange nozzle a support collar is used. This variant requires an on-site machining of the collar to assure an interference fit in flange nozzles (see Technical information IN 00.26)



ScrutonWell®

The ScrutonWell® design reduces the amplitude of oscillation by more than 90 % 1) and allows an easy and fast installation of the thermowell without support collar.

The WIKA ScrutonWell® design was proven with laboratory test by the Institute of Mechanics and Fluid Dynamics of the University of Freiberg.

The ScrutonWell® design can be used for all kind of solid-machined thermowells with flange connection, in Vanstone design or for weld-in or screwed process connection.

This helical design has been used successfully for decades in a wide variety of industrial applications to effectively suppress vortex-induced shrinkage excitation (see data sheet SP 05.16).



Model TW10 in ScrutonWell® design

Standard thermowell

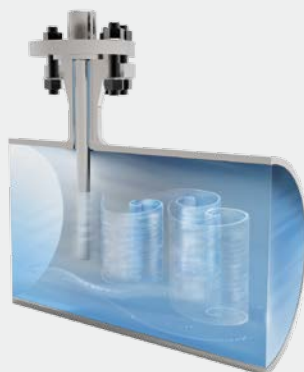

In certain flow conditions, a Kármán vortex street can form behind the thermowell stem when it is subjected to a flow within a pipeline. This vortex street consists of two rows of vortices with opposite directions of rotation, which detach themselves to the left and the right of the thermowell out of phase, and this can instigate the thermowell to vibrate.

Thermowell in ScrutonWell® design

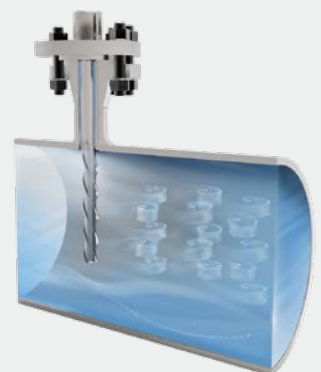

The helical coils, arranged around the thermowell stem of the ScrutonWell® design, break up the flow and thus impede the formation of a clearly defined Kármán vortex street. Through the reduced amplitudes of the diffused vortices, vibrational excitation of the thermowell is avoided.

Level measuring instruments



BNA

Bypass level indicator



- Material:** Austenitic steels, 6Mo, Hastelloy, titanium, Monel, Inconel, Incoloy, Duplex, Super Duplex
- Process connection:** ■ Flange: DIN, ANSI, EN
■ Thread
■ Weld stub
- Temperature:** -160 ... +450 °C
- Density:** ≥ 400 kg/m³
- Data sheet:** LM 10.01

FLR

Level sensor with reed-chain technology



- Process connection:** ■ Mounting thread
■ Flange: DIN, ANSI, EN
- Guide tube length:** Max. 6,000 mm
- Pressure:** 0 ... 200 bar
- Temperature:** -80 ... +200 °C
- Density:** ≥ 400 kg/m³
- Data sheet:** LM 20.02

LGG

Sight glass level indicator



Material: Forged steel, heat-resistant C-steel, stainless steel, Monel, Hastelloy
Design: Available as welded, glass tube, reflection, transparent and refraction indicators
Pressure: 0 ... 250 bar
Temperature: -200 ... +400 °C
Data sheet: LM 33.01

FLS

Magnetic float switch



Switch points: Max. 8 switch points
Process connection: ■ Mounting thread
 ■ Flange: DIN, ANSI, EN
Guide tube length: Max. 6,000 mm
Pressure: 0 ... 100 bar
Temperature: -196 ... +300 °C
Density: $\geq 390 \text{ kg/m}^3$
Data sheet: LM 30.01

FLM

Level sensor, magnetostrictive, high-resolution measuring principle



Switch points: Max. 8 switch points
Process connection: ■ Mounting thread
 ■ Flange: DIN, ANSI
Guide tube length: Max. 5,800 mm
Pressure: 0 ... 100 bar
Temperature: -90 ... +400 °C
Density: $\geq 400 \text{ kg/m}^3$
Data sheet: LM 20.01

OLS-C20

Optoelectronic level switch - compact design



Material: Stainless steel, quartz glass
Process connection: ■ M16 x 1.5
 ■ G 1/2 A
 ■ 1/2 NPT
Insertion length: 24 mm
Pressure: 0 ... 50 bar
Temperature: -30 ... +135 °C
Data sheet: LM 31.02

OLS-S, OLS-H

Optoelectronic level switch, standard/high-pressure version



Material: Stainless steel, Hastelloy, KM-glass, quartz glass, sapphire, graphite
Process connection: ■ G 1/2 A
 ■ 1/2 NPT
Pressure: 0 ... 500 bar
Temperature: -269 ... +400 °C
Data sheet: LM 31.01

OSA-S

Switching amplifier for optoelectronic level switch models OLS-S/OLS-H



Output: 1 signal relay, 1 failure relay
Function: High or low alarm
Time delay: Up to 8 s
Voltage supply: AC 230 V / 24/115/120 A
 DC 24 V
Data sheet: LM 31.01

Flow measuring instruments

Primary flow elements

The most common way to measure flow is differential-pressure flow measurement. This measuring principle has proven itself over many years and is applicable for all common types of media.

Our portfolio of primary flow elements includes orifice plates, orifice assemblies, meter runs and Venturi tubes.

Pressure drop

When using a differential pressure flow meter a permanent pressure drop is always generated. The graph shows a comparison between the different types of differential-pressure flow measurement instruments. Pressure loss is shown as a percentage of the measured differential pressure.

The graph can assist in the selection of the best instrument for your application.

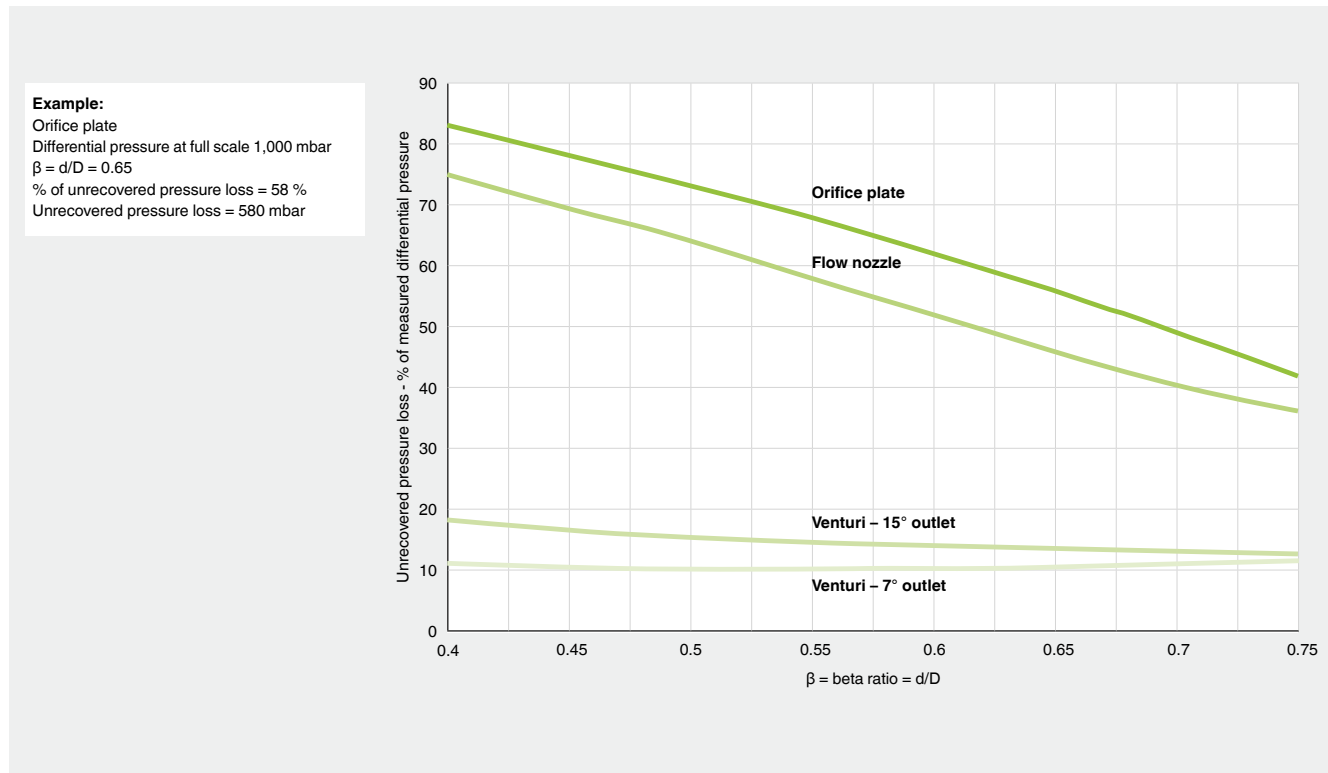

Medium characteristics

Not all instruments can be used in all applications. The type of medium (gas, liquid or steam) and its conditions must be taken into account when selecting the right instrument for your medium condition.

The following selection chart will assist in choosing the right instrument:

| | | Orifice plate and related assemblies (Orifice flange / Meter run / Annular chambers) | | | | | Flow nozzle | Venturi tube | Pitot tube |
|--------|-----------|---|----------------|------------------|-----------|-----------|-------------|--------------|------------|
| | | Square edge | Quarter circle | Conical entrance | Eccentric | Segmental | | | |
| Gas | Clean | ++ | - | - | + | + | ++ | ++ | ++ |
| | Dirty | - | - | - | ++ | ++ | + | + | - |
| Liquid | Clean | ++ | ++ | ++ | + | + | ++ | ++ | ++ |
| | Viscous | - | ++ | ++ | - | - | + | + | + |
| | Dirty | + | + | + | ++ | ++ | + | + | - |
| | Corrosive | + | + | + | + | + | + | + | + |
| Steam | | + | + | + | + | + | ++ | + | - |

++ Preferred + Suitable - Not suitable

Reynolds number

It is difficult to evaluate the many variables affecting the velocity profile for all flow meters and for all pipeline conditions. To combine medium properties (density and viscosity), flow rate and geometrical aspects the Reynolds number is used.

| | | Dimensions | | Reynolds number |
|---|------------------|------------|-------|-----------------|
| | | N | ND | |
| Orifice plate and related assemblies | Integral | < 1.5" | < 40 | > 100 |
| | Square edge | > 1.5" | > 40 | > 2,000 |
| | Quarter circle | > 1.5" | > 40 | > 200 |
| | Conical entrance | > 1.5" | > 40 | > 200 |
| | Eccentric | > 4" | > 100 | > 10,000 |
| Orifice flange Meter run Annular chambers | Segmental | > 4" | > 100 | > 1,000 |
| Flow nozzle | | > 2" | > 50 | > 75,000 |
| Venturi tube | | > 2" | > 50 | > 12,500 |
| Pitot tube | | > 4" | > 100 | no limits |

The table shows you the smallest possible Reynolds number that can be used with each instrument.

Flow measuring instruments

FLC-VT-BAR

Venturi tube, bar body



Pipe size: ■ 2 ... 32 in
 ■ 50 ... 250 mm
 β : 0.4 ... 0.75
 Measuring deviation
 1): Uncalibrated ± 1.25 %
 Data sheet: FL 10.04

FLC-VT-WS

Venturi tube, welded sheet



Pipe size: ■ ≥ 14 in
 ■ 200 ... 1,200 mm
 β : 0.4 ... 0.7
 Measuring deviation
 1): Uncalibrated ± 1.5 %
 Data sheet: FL 10.04

FLC-OP

Orifice plate



Standards: ■ ISO 5167-2
 ■ ASME MFC3M
 Pipe size: ■ ≥ 2 "
 ■ ≥ 50 mm
 β : Depending on version
 Measuring deviation
 1): Uncalibrated ± 0.5 ... 2.5 %
 Data sheet: FL 10.01

FLC-FL

Orifice flanges



Standards: ISO 5167-2
 Pipe size: ■ ≥ 2 "
 ■ ≥ 50 mm
 β : Depending on version
 Measuring deviation
 1): Uncalibrated ± 0.5 ... 2.5 %
 Data sheet: FL 10.01

FLC-AC

Annular chambers



Standards: ISO 5167-2
 Pipe size: ■ ≥ 2 "
 ■ ≥ 50 mm
 β : Depending on version
 Measuring deviation
 1): Uncalibrated ± 0.5 ... 2.5 %
 Data sheet: FL 10.01

FLC-MR

Meter run



Standards: ISO 5167-2
 Pipe size: ■ $\frac{1}{2}$... 1½ in
 ■ 12 ... 40 mm
 β : 0.2 ... 0.75
 Measuring deviation
 1): Uncalibrated ± 1 ... 2 %
 Data sheet: FL10.02

Restriction orifices

When the process requires a pressure drop, a restriction orifice can be installed in the line. The design must take into consideration the flow conditions, and the differential pressure required to avoid issues (cavitation, choking and noise).

Single- or multi-step restriction orifice solutions are selected depending on the differential pressure and medium. Single-bore or multi-bore options must be selected to ensure an acceptable noise level.

When a reduction of pressure or a limitation of the flow rate is required, a restriction orifice must be inserted into the pipeline. Our technical department will produce the correct design for the restriction orifice, depending on customer requirements and flow conditions.

If high differential pressures, a change in phase or sonic issues can occur, a more-complex design will be required. The solution in these cases is to decrease the differential pressure in several steps, avoiding all the issues created by these factors. This solution is called multi-step restriction orifice.

Main characteristics

- Multi-step restriction orifices to reduce the pressure by more than 50 % of the inlet value
- Multi-bore designs to reduce the noise level

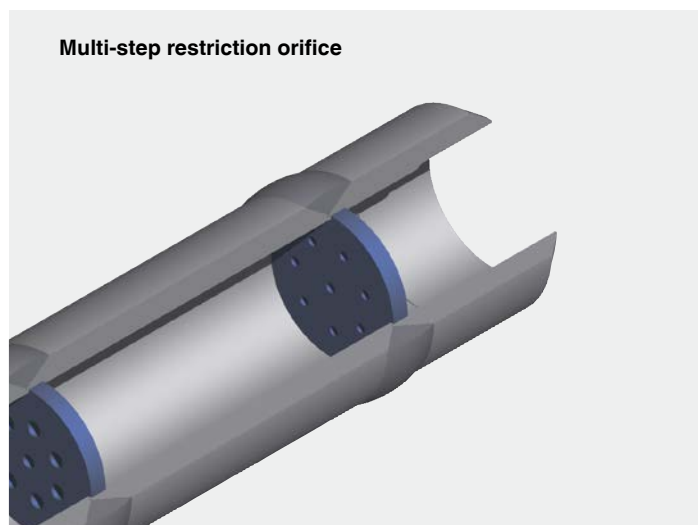

FLC-RO-ST

Single-step restriction orifice



Data sheet: FL 20.01

FLC-RO-MS

Multi-step restriction orifice



Data sheet: FL 20.01

Calibration technology

From individual components ...

WIKA is the ideal partner for solutions in calibration technology, whether only a single service instrument is required quickly on site, or whether a fully automated calibration system needs to be designed for the laboratory or production.

We are able to offer an appropriate solution for each application. In relation to the measuring task and the measurement parameters, the following product matrix will assist you.



Portable pressure generation

Test pumps serve as pressure generators for the testing of mechanical and electronic pressure measuring instruments through comparative measurements. These pressure tests can take place in the laboratory or workshop, or on site at the measuring point.



Measuring components

High-precision pressure sensors and very stable standard thermometers are ideal for applications as references in industrial laboratories. Due to their analogue or digital interfaces they can be connected to existing evaluation instruments.



Hand-helds, calibrators

Our hand-held measuring instruments (process tools) offer a simple capability for measurement or simulation of all established measurement parameters on site. They can be operated with a wide variety of pressure sensors or thermometers.



... to a fully automated system



Digitally indicating precision measuring instruments

High-precision digital precision measuring instruments are ideal for applications as reference standards in industrial laboratories, enabling high-accuracy calibration. They feature exceptionally simple handling and an extensive range of functionality.



Digital precision instruments and controllers

Due to their integrated controller, these instruments offer exceptional convenience. Typically, a fully automated setting of the required value can be set via the interface.



Fully automatic calibration systems as integrated solutions

Fully automated calibration systems are customer-specific, turnkey installations which can be fitted in laboratories as well as in the production environment. With integrated reference instruments and calibration software, calibration certificates can be generated and archived in a simple and reproducible way.



■ Pressure ■ temperature ■ current, voltage, resistance

Calibration services

Our calibration laboratory has been accredited for pressure since 1982 and for temperature since 1992 in accordance with DIN EN ISO/IEC 17025. Since 2014, our calibration laboratory has also been accredited for the electrical measurement parameters DC current, DC voltage and DC resistance.

From -1 bar ... +8,000 bar

D-K-15105-01-00

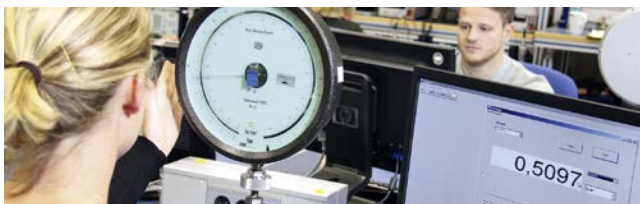

We calibrate your pressure measuring instruments quickly and precisely:

- in the range from -1 bar ... +8,000 bar
- using high-precision reference standards (pressure balances) and working standards (precise electrical pressure measuring instruments)
- with an accuracy from 0.003 % ... 0.01 % of reading depending on the pressure range
- in accordance with the directives DIN EN 837, DAkkS-DKD-R 6-1, EURAMET cg-3 or EURAMET cg-17

From -196 °C ... +1,200 °C

D-K-15105-01-00

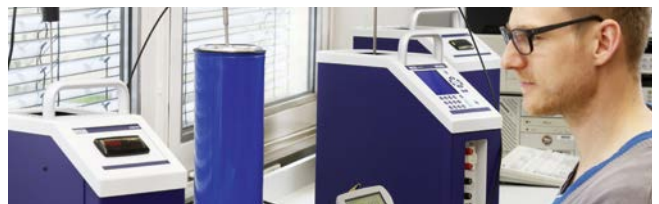

We calibrate your temperature measuring instruments quickly and precisely:

- in the range from -196 °C ... +1,200 °C
- in calibration baths, tube furnaces or at fixed points using appropriate reference thermometers
- with an accuracy of 2 mK ... 1.5 K depending on temperature and the procedure
- in accordance with the appropriate DKD/DAkkS and EURAMET directives

Electrical measurement parameters

D-K-15105-01-00



We calibrate your electrical measuring instruments quickly and precisely:

- DC current in the range 0 mA ... 100 mA
- DC voltage in the range 0 V ... 100 V
- DC resistance in the range 0 Ω ... 10 kΩ
- in accordance with the directives: VDI/VDE/DGQ/DKD 2622

On-site calibration

D-K-15105-01-00



In order to have the least possible impact on the production process, we offer you a time-saving, on-site DAkkS calibration throughout Germany (measurement parameter pressure).

We calibrate your pressure and temperature measuring instruments quickly and precisely:

- in our calibration van or on your workbench
- with a DAkkS accreditation for pressure
 - in the range of -1 bar ... +8,000 bar
 - with accuracies between 0.025 % and 0.1 % of FS for the standard used
- Inspection certificates 3.1 for the measurement parameter temperature from -55 ... +1,100 °C

WIKA worldwide

Europe

Austria
WIKA Messgerätevertrieb
Ursula Wiegand GmbH & Co. KG
Perfektastr. 73
1230 Vienna
Tel. +43 1 8691631
Fax: +43 1 8691634
info@wika.at
www.wika.at

Belarus
WIKA Belarus
Ul. Zaharova 50B, Office 3H
220088 Minsk
Tel. +375 17 2945711
Fax: +375 17 2945711
info@wika.by
www.wika.by

Benelux
WIKA Benelux
Industrial estate De Berk
Newtonweg 12
6101 WX Echt
Tel. +31 475 535500
Fax: +31 475 535446
info@wika.nl
www.wika.nl

Bulgaria
WIKA Bulgaria EOOD
Akad.Ivan Geshov Blvd. 2E
Business Center Serdika, office 3/104
1330 Sofia
Tel. +359 2 82138-10
Fax: +359 2 82138-13
info@wika.bg
www.wika.bg

Croatia
WIKA Croatia d.o.o.
Hrastovka 19
10250 Zagreb-Lucko
Tel. +385 1 6531-034
Fax: +385 1 6531-357
info@wika.hr
www.wika.hr

Finland
WIKA Finland Oy
Melkonkatu 24
00210 Helsinki
Tel. +358 9 682492-0
Fax: +358 9 682492-70
info@wika.fi
www.wika.fi

France
WIKA Instruments s.a.r.l.
Parc d'Affaires des Bellevues
8 rue Rosa Luxembourg
95610 Eragny-sur-Oise
Tel. +33 1 343084-84
Fax: +33 1 343084-94
info@wika.fr
www.wika.fr

Germany
WIKA Alexander Wiegand SE & Co. KG
Alexander-Wiegand-Str. 30
63911 Klingenberg
Tel. +49 9372 132-0
Fax: +49 9372 132-406
info@wika.de
www.wika.de

Italy
WIKA Italia S.r.l. & C. S.a.s.
Via G. Marconi 8
20020 Arese (Milano)
Tel. +39 02 93861-1
Fax: +39 02 93861-74
info@wika.it
www.wika.it

Poland
WIKA Polska spółka z ograniczoną
odpowiedzialnością sp. k.
Ul. Legska 29/35
87-800 Wloclawek
Tel. +48 54 230110-0
Fax: +48 54 230110-1
info@wikapolska.pl
www.wikapolska.pl

WIKA Alexander Wiegand SE & Co. KG
Alexander-Wiegand-Straße 30 · 63911 Klingenberg · Germany
Tel. +49 9372 132-0 · Fax +49 9372 132-406
info@wika.de · www.wika.de

North America

Canada
WIKA Instruments Ltd.
Head Office
3103 Parsons Road
Edmonton, Alberta, T6N 1C8
Tel. +1 780 4637035
Fax: +1 780 4620017
info@wika.ca
www.wika.ca

USA
WIKA Instrument, LP
1000 Wiegand Boulevard
Lawrenceville, GA 30043
Tel. +1 770 5138200
Fax: +1 770 3385118
info@wika.com
www.wika.com

Gayesco-WIKA USA, LP
229 Beltway Green Boulevard
Pasadena, TX 77503
Tel. +1 713 47500-22
Fax: +1 713 47500-11
info@wikahouston.com
www.wika.us

Mensor Corporation
201 Barnes Drive
San Marcos, TX 78666
Tel. +1 512 396-4200
Fax: +1 512 396-1820
sales@mensor.com
www.wika.com

Latin America

Argentina
WIKA Argentina S.A.
Gral. Lavalle 3568
(B1603AUH) Villa Martelli
Buenos Aires
Tel. +54 11 47301800
Fax: +54 11 47610050
info@wika.com.ar
www.wika.com.ar

Brazil
WIKA do Brasil Ind. e Com. Ltda.
Av. Ursula Wiegand, 03
CEP 18560-000 Iperó - SP
Tel. +55 15 34599700
Fax: +55 15 32661650
vendas@wika.com.br
www.wika.com.br

Chile
WIKA Chile S.p.a.
Av. Coronel Pereira 72
Oficina 101
Las Condes - Santiago de Chile
Tel. +56 2 365-1719
info@wika.cl
www.wika.cl

Colombia
Instrumentos WIKA Colombia S.A.S.
Dorado Plaza,
Avenida Calle 26 No. 85D - 55
Local 126 y 126 A
Bogotá - Colombia
Tel. +57 1 744 3455
info@wika.co
www.wika.co

Mexico
Instrumentos WIKA Mexico
S.A. de C.V.
Vienna 20 Ofina 301
Col. Juarez, Del. Cuauhtemoc
06600 Mexico D.F.
Tel. +52 55 50205300
Fax: +52 55 50205300
ventas@wika.com
www.wika.com.mx

Asia

Azerbaijan
WIKA Azerbaijan LLC
Caspian Business Center
9th floor 40 J.Jabbarli str.
AZ1065 Baku
Tel. +994 12 49704-61
Fax: +994 12 49704-62
info@wika.az
www.wika.az

China
WIKA Instrumentation Suzhou Co., Ltd.
81, Ta Yuan Road, SND
Suzhou 215011
Tel. +86 512 6878 8000
Fax: +86 512 6809 2321
info@wika.cn
www.wika.com.cn

India
WIKA Instruments India Pvt. Ltd.
Village Kesnard, Wagholi
Pune - 412 207
Tel. +91 20 66293-200
Fax: +91 20 66293-325
sales@wika.co.in
www.wika.co.in

Iran
WIKA Instrumentation Pars Kish
(KFZ) Ltd.
Apt. 307, 3rd Floor
8-12 Vanak St., Vanak Sq., Tehran
Tel. +98 21 88206-596
Fax: +98 21 88206-623
info@wika.ir
www.wika.ir

Japan
WIKA Japan K. K.
MG Shibaura Bldg. 6F
1-8-4, Shibaura, Minato-ku
Tokyo 105-0023
Tel. +81 3 5439-6673
Fax: +81 3 5439-6674
info@wika.co.jp
www.wika.co.jp

Kazakhstan
TOO WIKA Kazakhstan
Raimbekstr. 169, 3rd floor
050050 Almaty
Tel. +7 727 2330848
Fax: +7 727 2789905
info@wika.kz
www.wika.kz

Korea
WIKA Korea Ltd.
39 Gajangsaneopseo-ro Osan-si
Gyeonggi-do 447-210
Tel. +82 2 86905-05
Fax: +82 2 86905-25
info@wika.co.kr
www.wika.co.kr

Malaysia
WIKA Instrumentation M Sdn. Bhd.
No. 27 & 29 Jalan Puteri 5/20
Bandar Puteri Puchong
47100 Puchong, Selangor
Tel. +60 3 806310-80
Fax: +60 3 806310-70
info@wika.com.my
www.wika.com.my

Philippines
WIKA Instruments Philippines, Inc.
Unit 102 Skyway Twin Towers
351 Capt. Henry Javier St.
Bgy. Oranbo, Pasig City 1600
Tel. +63 2 234-1270
Fax: +63 2 695-9043
info@wika.com.ph
www.wika.com.ph

Singapore
WIKA Instrumentation Pte. Ltd.
13 Kian Teck Crescent
628878 Singapore
Tel. +65 6844 5506
Fax: +65 6844 5507
info@wika.com.sg
www.wika.com.sg

Taiwan
WIKA Instrumentation Taiwan Ltd.
Min-Tsu Road, Pinjen
32451 Taoyuan
Tel. +886 3 420 6052
Fax: +886 3 490 0080
info@wika.com.tw
www.wika.com.tw

Thailand
WIKA Instrumentation Corporation
(Thailand) Co., Ltd.
850/7 Ladkrabang Road, Ladkrabang
Bangkok 10520
Tel. +66 2 32668-73
Fax: +66 2 32668-74
info@wika.co.th
www.wika.co.th

Africa / Middle East

Egypt
WIKA Near East Ltd.
Villa No. 6, Mohamed Fahmy
Elmohdar St. - of Eltayaran St.
1st District - Nasr City - Cairo
Tel. +20 2 240 13130
Fax: +20 2 240 13113
info@wika.com.eg
www.wika.com.eg

Namibia
WIKA Instruments Namibia Pty Ltd.
P.O. Box 31263
Pionierspark
Windhoek
Tel. +26 4 61238811
Fax: +26 4 61233403
info@wika.com.na
www.wika.com.na

South Africa
WIKA Instruments Pty. Ltd.
Chilvers Street, Denver
Johannesburg, 2094
Tel. +27 11 62100-00
Fax: +27 11 62100-59
sales@wika.co.za
www.wika.co.za

United Arab Emirates
WIKA Middle East FZE
Warehouse No. RB08JB02
P.O. Box 17492
Jebel Ali, Dubai
Tel. +971 4 883-9090
Fax: +971 4 883-9198
info@wika.ae
www.wika.ae

Australia

Australia
WIKA Australia Pty. Ltd.
Unit K, 10-16 South Street
Rydalmere, NSW 2116
Tel. +61 2 88455222
Fax: +61 2 96844767
sales@wika.com.au
www.wika.com.au

New Zealand
WIKA Instruments Limited
Unit 7 / 49 Sainsbury Road
St Lukes - Auckland 1025
Tel. +64 9 8479020
Fax: +64 9 8465964
info@wika.co.nz
www.wika.co.nz



Part of your business